



Creatives Get Mutual Summit:

Practical Tools for Building Collaborative Enterprise

6 June, 9am-5pm

Peace Embassy, 826 George St (cnr Regent St),
Chippendale NSW 2008





Keynote address

Creative co-operatives will change the world

Janelle Orsi

Co-founder and Executive Director of the Sustainable Economies Law Center (SELC)





MONOPOLY

GO



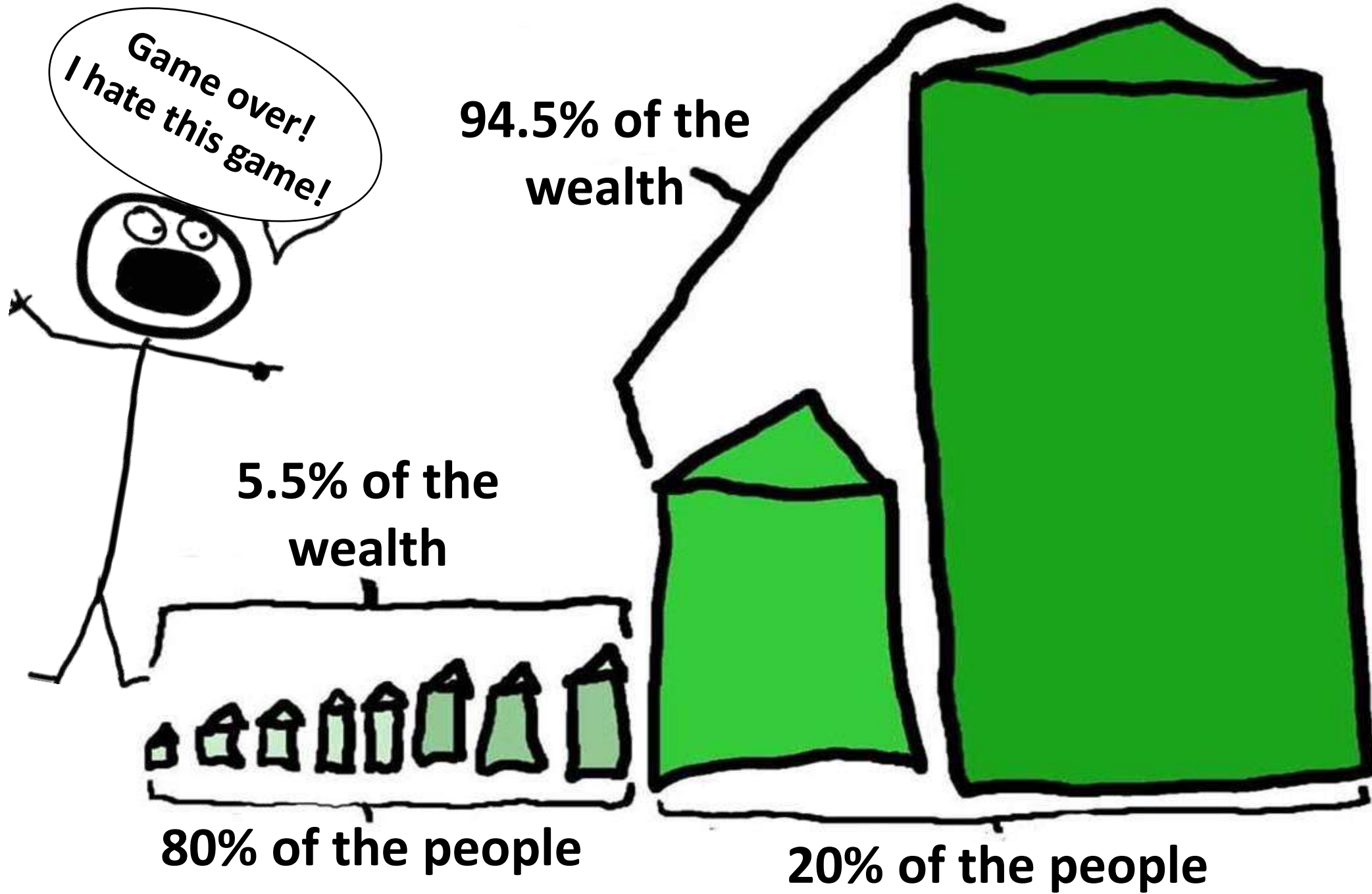

LET'S
CHANGE
THE RULES!

GO



Let's change this
archaic rule:

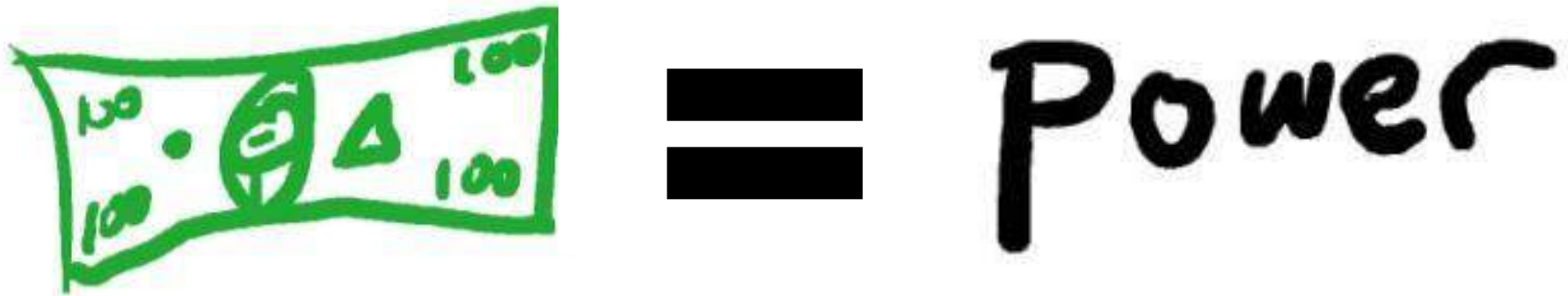

Another antiquated rule:



=



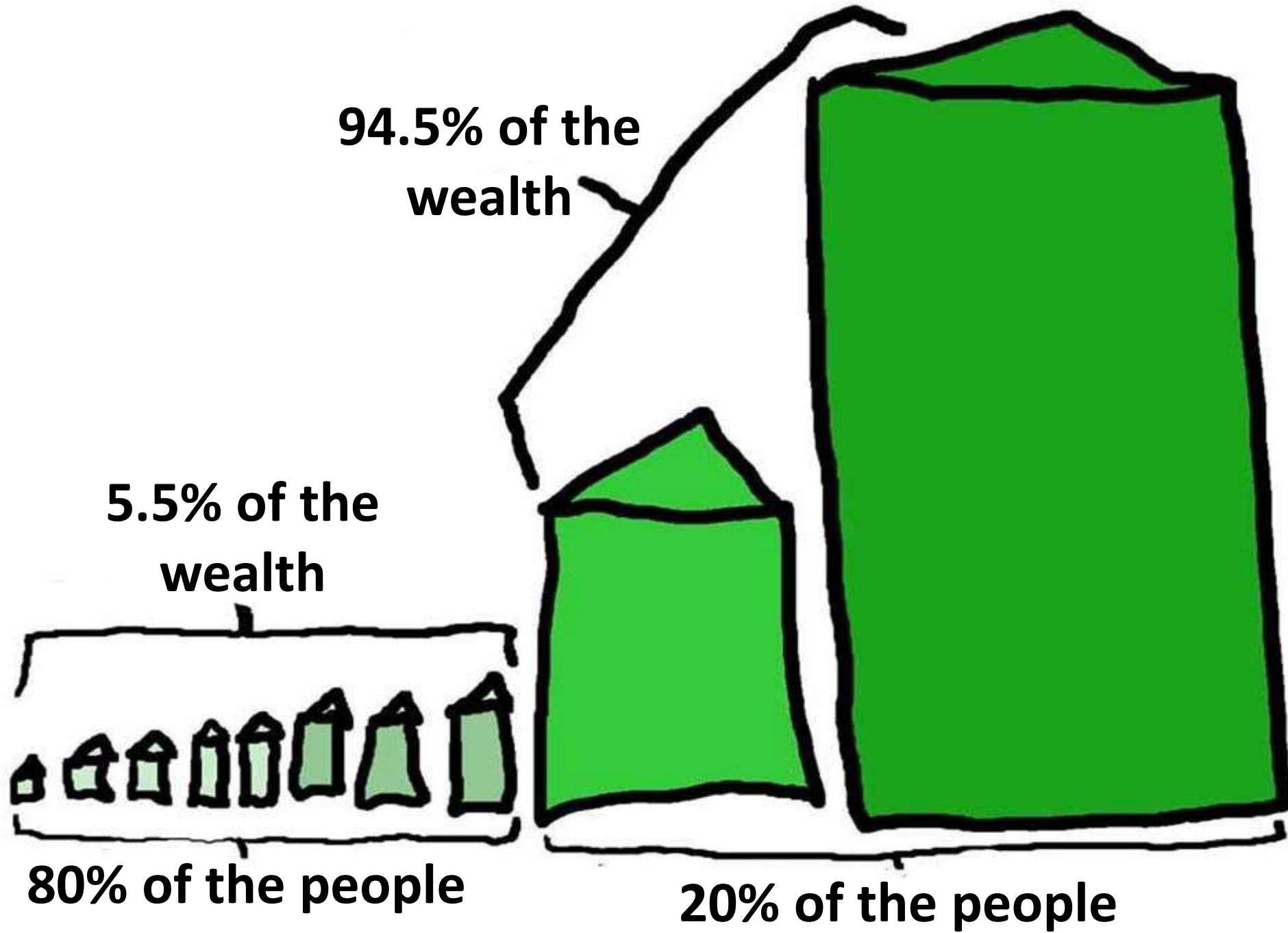

The 2 things to know about cooperatives:

1. Board elected on a one-member, one-vote basis.
Capital ownership doesn't determine voting power.



2. Profits distributed on the basis of patronage.
Capital ownership doesn't determine profit share.



Cooperatives:

Putting the Lively Back in Livelihoods



Worker Cooperatives

GRAPHIC DESIGN + VISUAL COMMUNICATIONS FOR PROGRESSIVE,
NON-PROFIT, & SOCIAL CHANGE ORGANIZATIONS.

OUR WORK

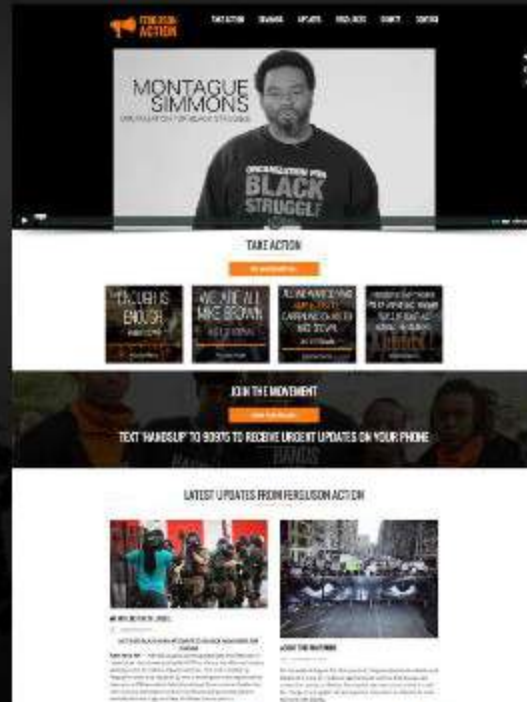



NEWSLETTER SIGNUP

DONATE



Sustainable Economies Law Center

- About Us ▾
- Resources ▾
- Events
- Get Involved ▾
- Blog
- Support ▾

- ### Programs
- Resilient Communities Legal Cafe
 - Food
 - Cooperatives
 - Community Enterprise
 - City Policies
 - Community Currencies
 - Community Renewable Energy
 - Rethinking Home
 - Work in the New Economy
 - Legal Profession in the New Economy



News



**Sustainable
Economies
Law Center**

Cooperative Work Spaces

What if one of the largest community centers and venue spaces in the Bay Area was run in a spirit of radical generosity, by a volunteer collective where everybody is a leader? We're trying to do just that, at the

Omni Commons

4799 Shattuck, Oakland, California

Join Us

About Us

We are thirteen Bay Area collectives with a shared political vision of more equitable commoning of resources and meeting human needs over private interests or corporate profit:

- **Agua Viva** is a worker-owned, cooperatively-run cafe that will serve as the convivial entrance to the Omni Commons.
- **Bay Area Public School** is a free, self-organizing, anti-capitalist school with radical and contestatory politics.
- **Birdhouse** is a new collective bringing art and artists to the Omni Commons.
- **Buried Seeds** is dedicated to the production & accessibility of Earth-based medicine.
- **Chiapas Support Committee** supports autonomous health care and education in Zapatista communities.
- **Counter Culture Labs** is a citizen science and DIYbio space that is open sourcing biology.
- **Food Not Bombs** has been bringing free food to parks, political events, neighborhood gatherings, and social centers since 1991.
- **Global Women's Strike - Omni Collective** is an international network working toward the return of military spending to the community starting with women, the main caregivers everywhere.
- **Liberated Lens** is a radical film & video collective dedicated to social change.
- **The Mess** is a theatre troupe and collective of writers, dancers, singers, actors, and mischiefmakers who are out to do comedy that is a reflection of the Bay Area's diverse culture.
- **Phat Beets** is a food justice group building farmers markets and gardens in North Oakland.
- **Sudo Room** is a place to build, learn, reclaim technology for the people, and create alternatives to the tech industry
- **Timeless, Infinite Light** is an Oakland small press focused on contemporary poetry and critical theory.



[site under live development]



STAY CONNECTED

Email Address:

connect

[Home](#) [Resident Artisans](#) [Artisan Vendors](#) [Happenings](#) [Oakland Sewn](#) [Venue Rental](#) [Studio Hours](#) [Press](#)

25C is a collective of Bay Area slow-food and slow-fashion artisans.

C

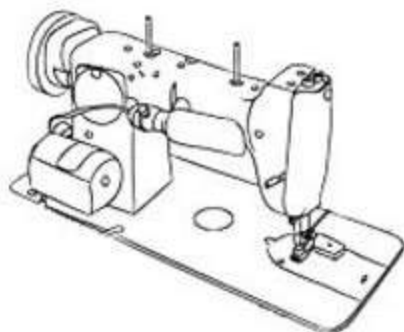

Oakland Sewn



Members



Vendors

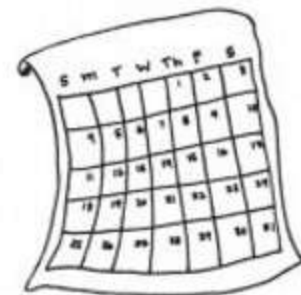

Your Special Event at the 25C

Heartwood Custom Woodworking

[Home](#)

[Woodworkers at Heartwood](#)

[About Us](#)

About Heartwood

Heartwood is a custom woodshop of seven woodworkers sharing a shop in Berkeley, California, where we have been since our founding in 1974. Some of us specialize in custom cabinetry, some in fine furniture. We work for homeowners and businesses, in all styles and finishes. We do design, construction, and installation.

Heartwood is a cooperative.

Andrew Benson, Tom Brown, John Curl, Erik Hopp, Moses Jones, Craig Smollen, Rick Moralez, Joel Chala.



Platform Cooperatives

The Middle "Man"

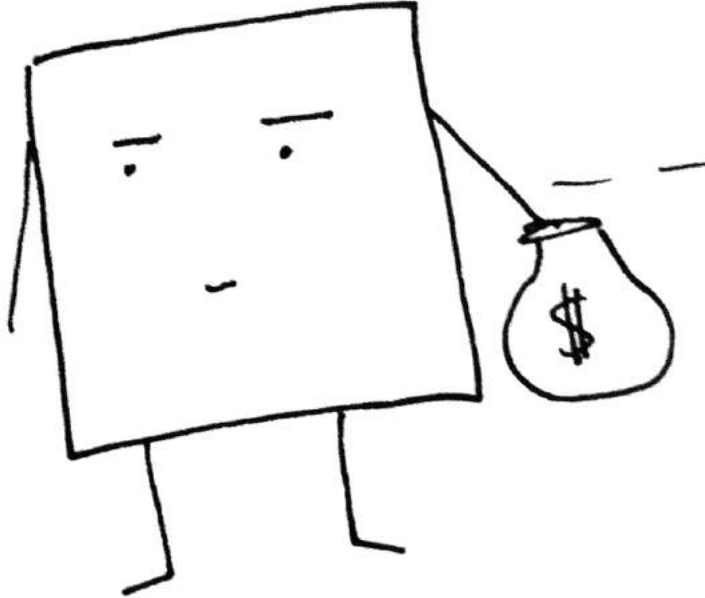

1. Technology

```
if { parameters.contains("name") + -  
= SQL } public.String = title _  
if ((!= null)) <Person> = System  
query + code.thing + stuff !!;
```

2. The captive
attention of a
lot of people:

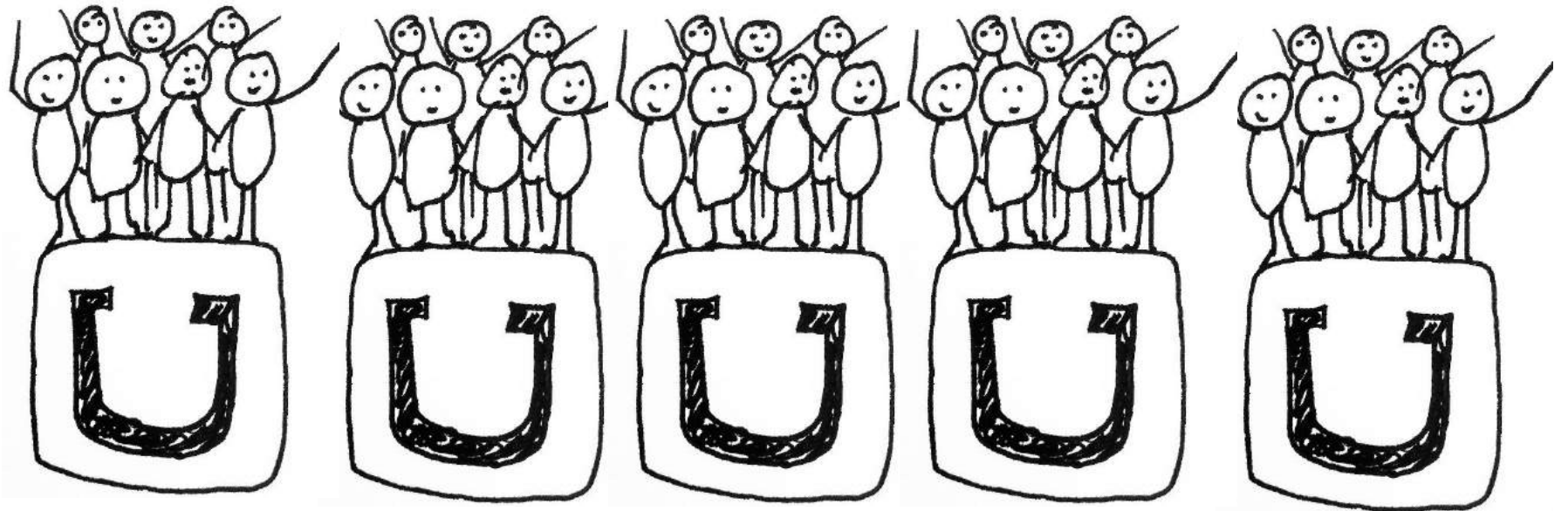

Good News

```
if { parameters.contains("name") + -  
= SQL } public.String = title_  
if ((!= null)) <Person> = System  
query + code.thing + stuff !!;
```

= clone

Good News

1. Organize!

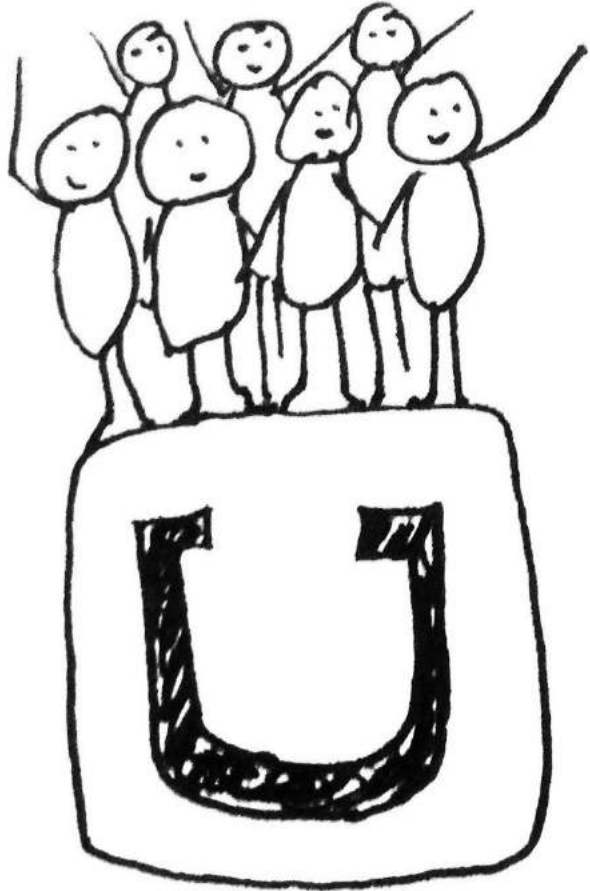

2. Leap!

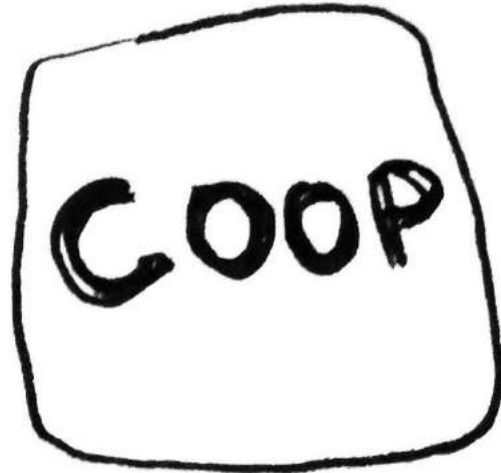

3. Delete!

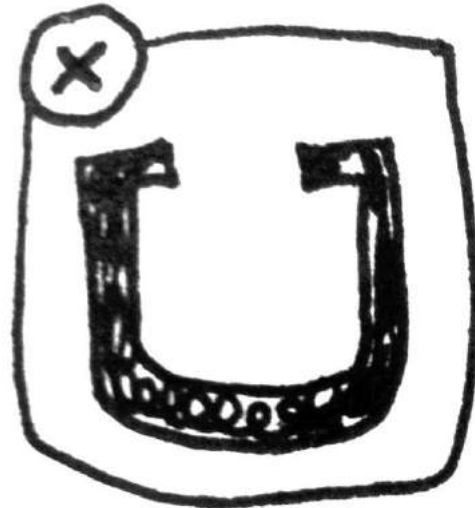

4. Repeat!

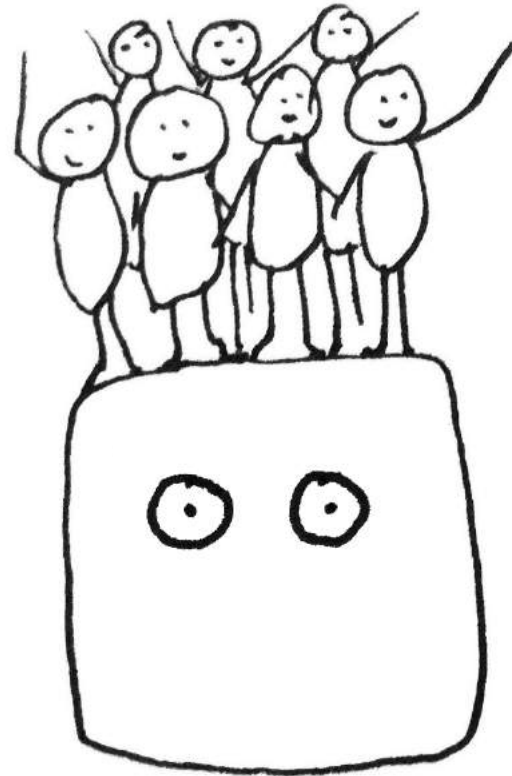

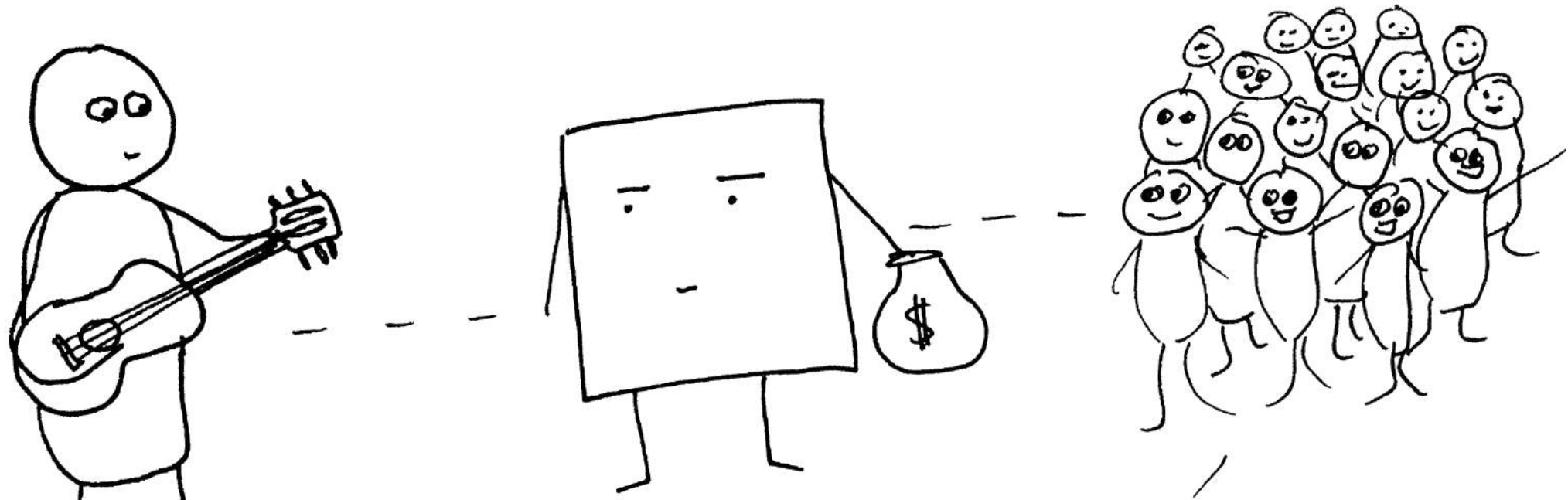

Cooperative

Good News

This is you.

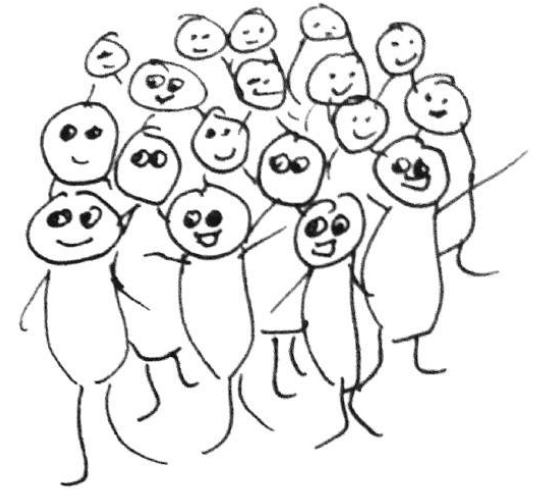
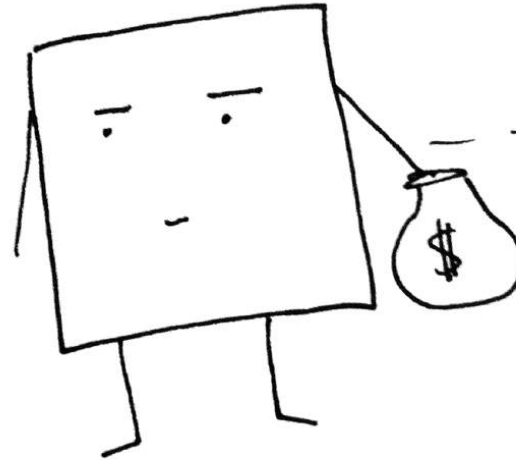

**And this is
you, too!**

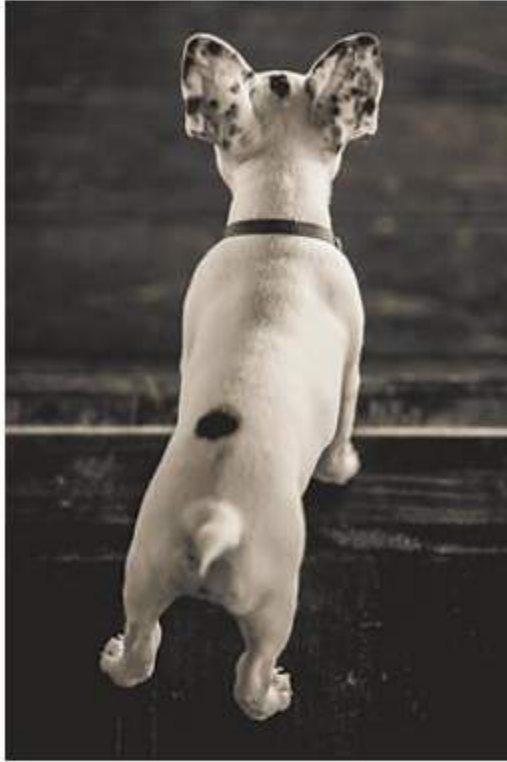



res()nate

fair music streaming

MEMBER'S MEDIA



CREATOR



COLLABORATOR

The Studio System
for
Independent
Narrative Media



SUPPORTER



MENTOR

NARRATIVE ACCELERATOR



- Story Development
- Creative Space
- Funding Support
- Project Promotions
- Collaborator Events
- Industry Mentorship

PROJECTED PRODUCTIONS

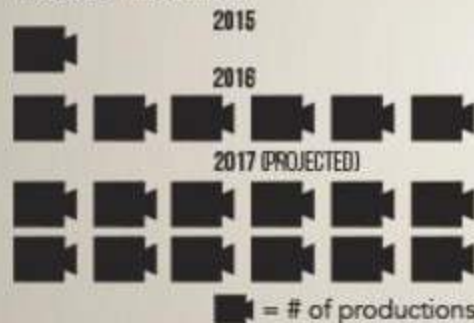

COOPERATIVE PRODUCTION

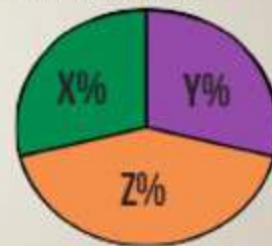

X% Creator | Y% Collaborators
Z% Fund Future Projects

High Value



Low Costs

Collaboration
OWNERSHIP
support
MICRO VISUAL ART
Audience
EPISODIC Act
Produce Create
COOPERATIVE
community
Distribute

FILM FUND



- Donation Based
- No Fees
- Development Awards
- Voted by Members

POWER



DISTRIBUTION SUPPORT



- Center-point Brand
- Marketing Efficiency
- ULTRA Engaged Audience
- Primed Demand

Our Motto

**BUILD IT.
USE IT.**



Now's the time.

A marketplace owned by the people doing the work.

Sign up for the beta

Browse by category



Home

Need some help around the house? Painters, housekeepers, handymen and more await you.

[View and book](#)



Child

Help your child learn a language, play an instrument, or give you a night out on the town.

[View and book](#)



Pet

Throw your dog a bone. Treat your pet to grooming services, walkers, sitters, and more.

[View and book](#)



Self Care

You need a massage. Personal trainers, music teachers, and a number of therapists are here.

[View and book](#)



Transport



Office

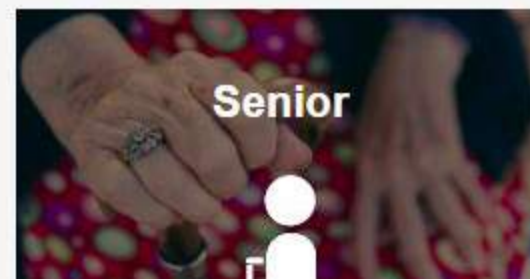

Senior



Celebration

#ThisShouldBeACooperative

The Etsy logo is positioned in the top left corner of the page. It features the word "Etsy" in a distinctive, orange, serif font. The background of the entire page is a vibrant orange, overlaid with a top-down view of a desk filled with various creative and office supplies, including a keyboard, a pen, a ruler, a calendar, and paintbrushes.

Search for items or shops

Search

[Sell on Etsy](#) [Regis](#)

Millions of shoppers can't wait to
see what you have in store

Open your Etsy shop



fuffernutter

Favorite shop



70
items

Favorite

Like this item?

Add it to your favorites to revisit it later.



cat book - cat illustrations - cat comics -
cat cartoons - black cat book

\$5.00

GST included (where applicable).

Quantity

1

Overview

- Handmade item
- Ships worldwide from United States
- Feedback: [188 reviews](#)
- Favorited by: [48 people](#)

This shop accepts Etsy gift cards

Recurring funding for artists and creators

Creators receive millions of dollars each month in support from their patrons



Learn More

Join Today

Home

Featured

Search

Become a Creator

We've started charging patrons for the monthly payments cycle. Please consult our newly updated [Help Center](#) if you have any question



Susie Cagle is creating illustrated labor journalism

Twitter

178 patrons

\$713 per creation

Become a patron

Mutual Aid and Exchange Cooperatives

OURGOODS

[Take the tour!](#)[Join us](#)[Sign in](#)

We are a barter network for the creative community. Our members trade skills, spaces and objects to get their work done without money.



We traded tools for fashion advice.

[Read More Stories](#)

What skills, spaces or objects do you need?

still

What if everyone had the opportunity
to build their skills to their maximum
capabilities and then apply them to
making their communities whole and
beautiful?

[@MutualAidN](#)



[eepurl](#)

[@MutualAidN](#)



[Join us](#)

[#NewE](#)

[summit this w](#)

[#MANmap20](#)

[bit.ly/1U74EZ](#)

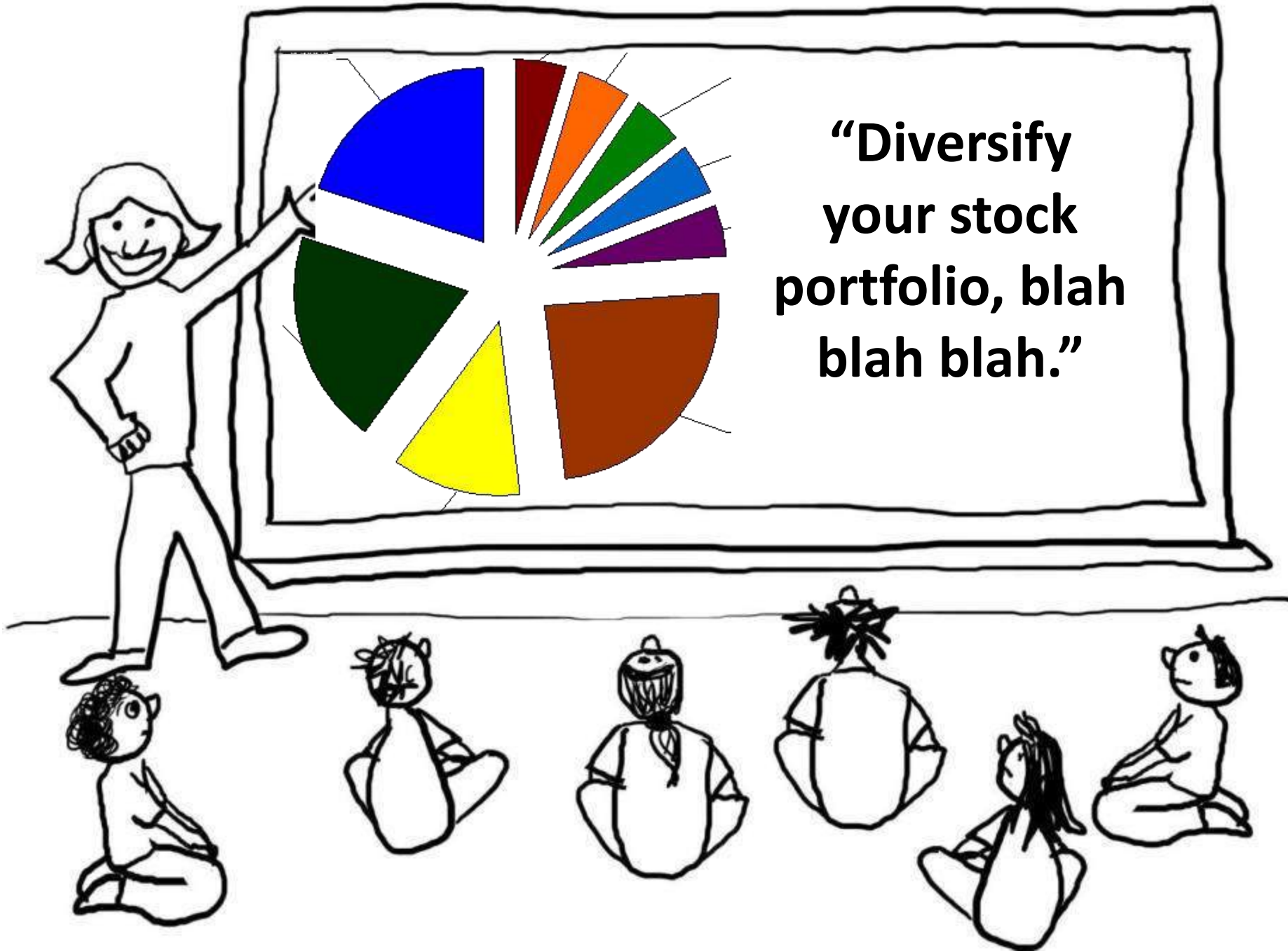

**“Diversify
your stock
portfolio, blah
blah blah.”**

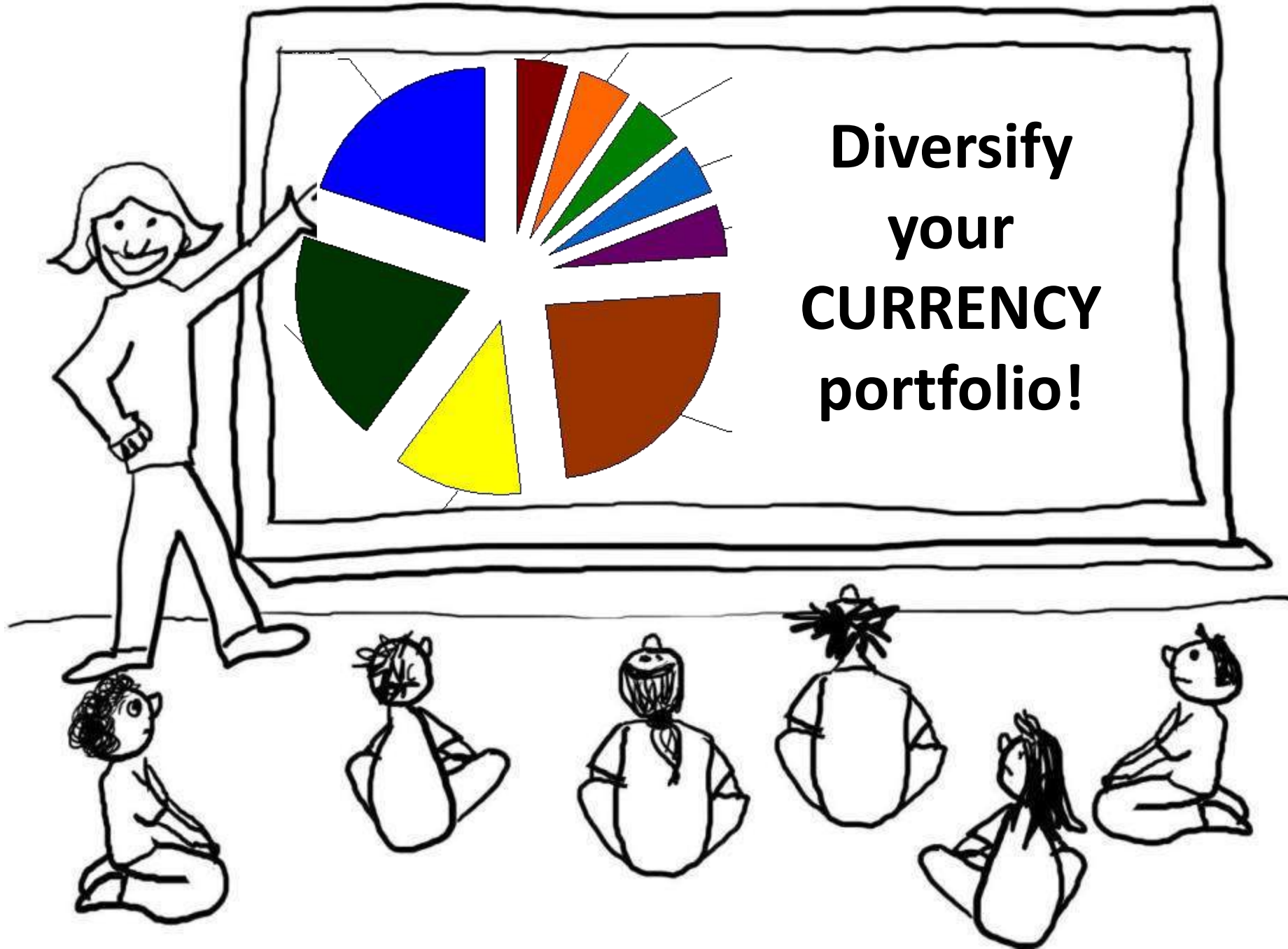

**Diversify
your
CURRENCY
portfolio!**

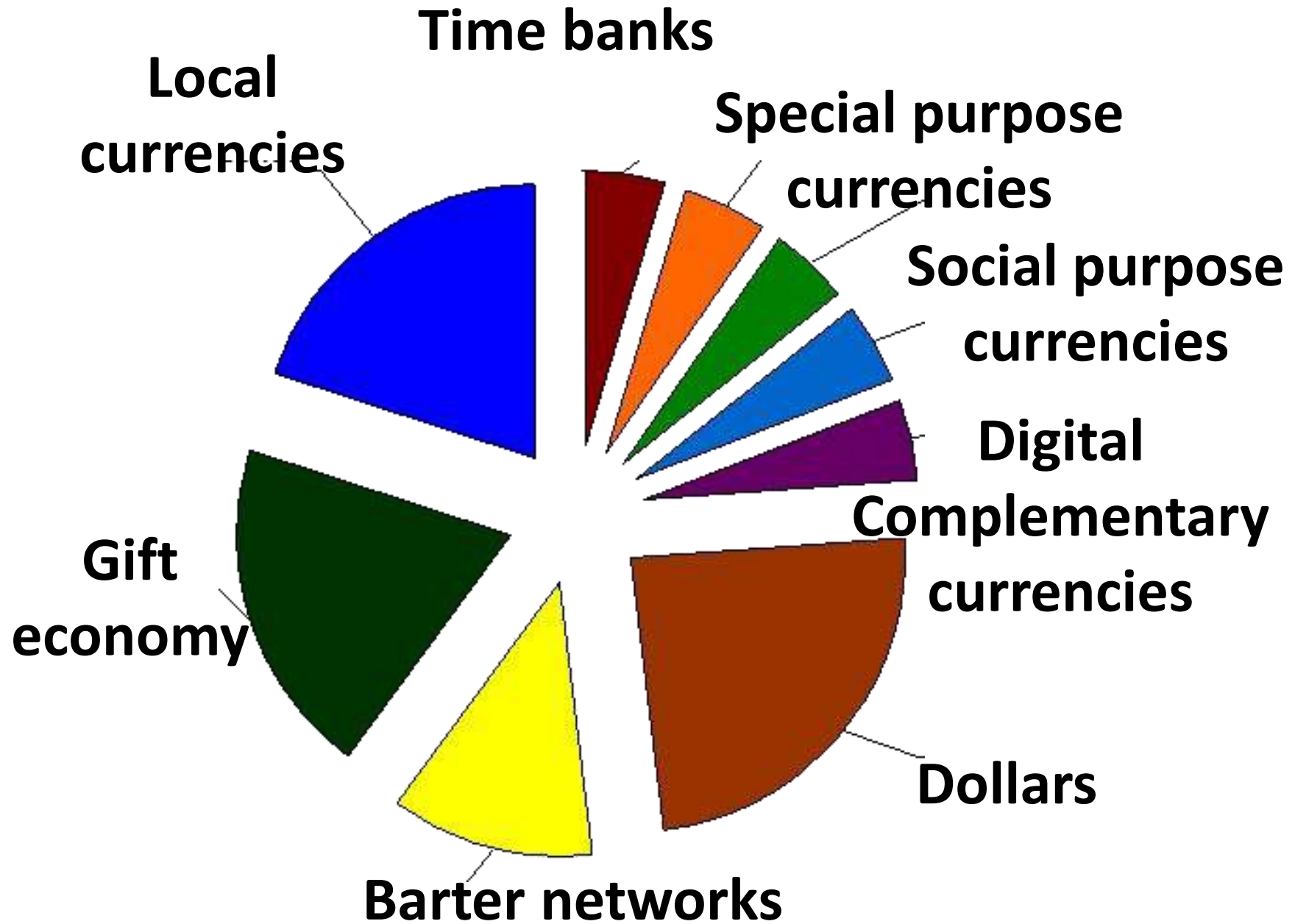

Consumer Solidarity Cooperatives



**Dollars are
people,
too.**

**Think about
that one...**

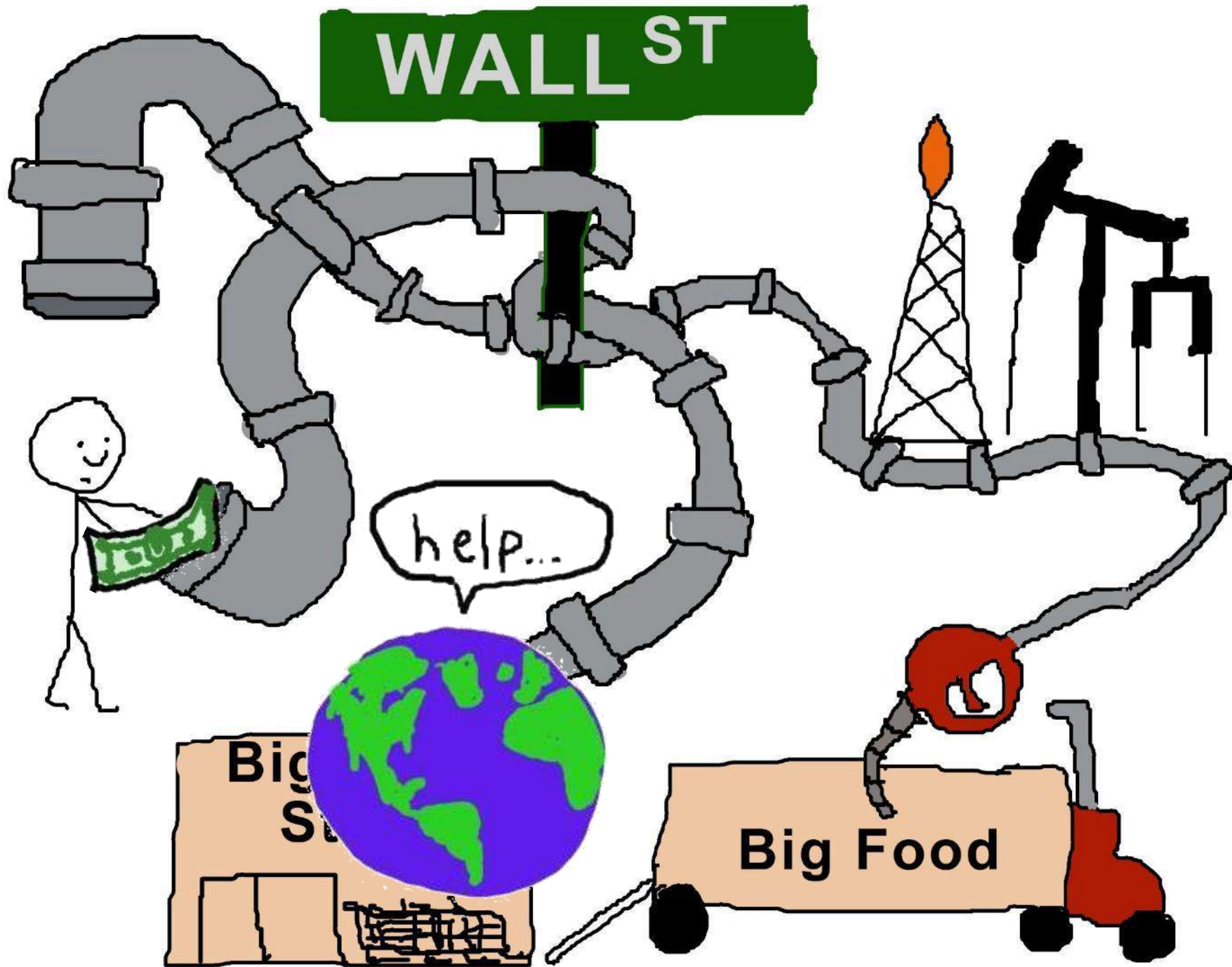

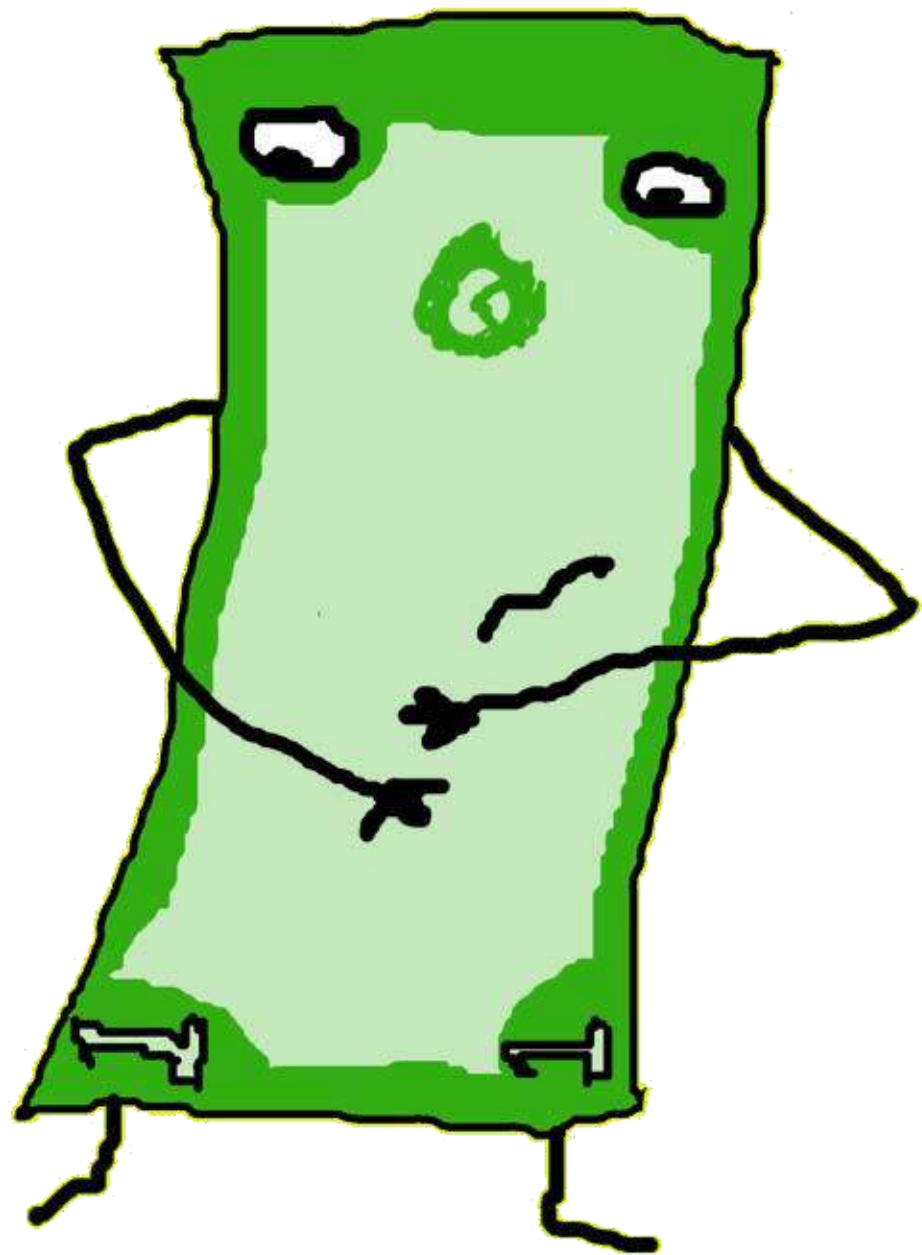















WALL ST



Community Supported Agriculture



Community Supported EVERYTHING!

- Share CAPITALIZATION
- Share PROFITS/BOUNTY
 - Share RISK
 - Share WORK/LABOR
 - Share INFORMATION
- Share DECISION-MAKING

I pledge to
spend \$1,000
on clothes from
East Bay Cooperatives



Hmm... Now
where can I
find an apparel
cooperative



Hey 100 acquaintances,
will you each
pledge to spend
\$1000 on clothes
from East Bay co-ops?



Let's form a
bargaining co-op
called Solidarity
Wear Cooperative
(or whatever...)

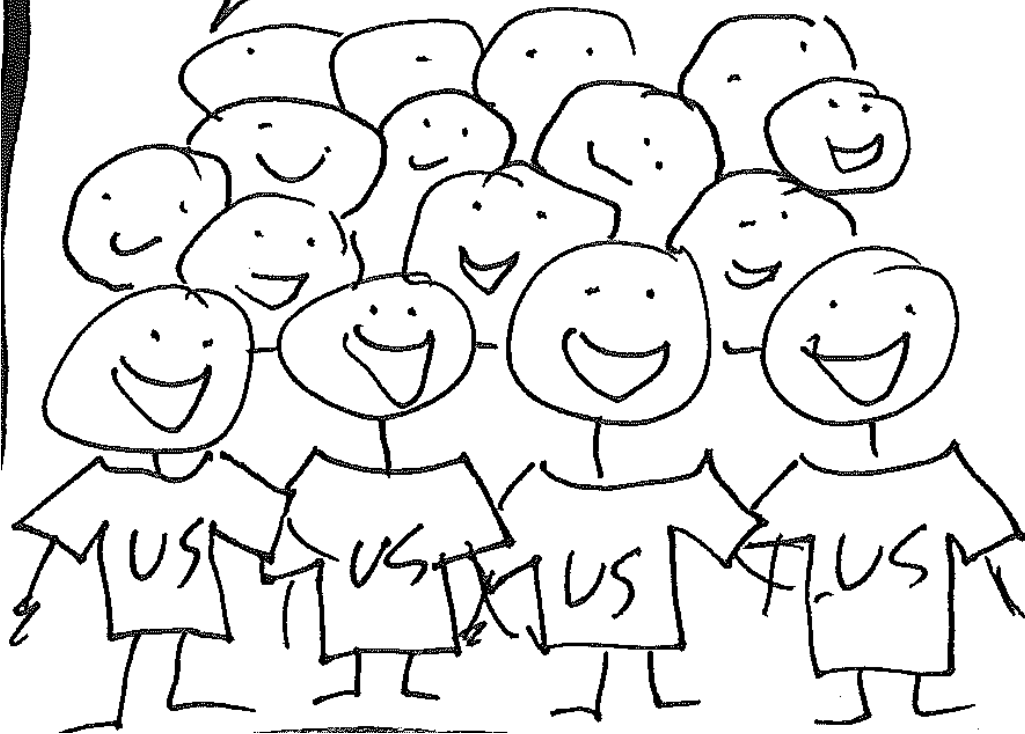

Let's make a list of
cool local
apparel
companies!



Payam
Myrrhia
Nan
Geana
etc...

Hey cool local
apparel company!
If you convert
to a worker co-op,
Solidarity Wear members
agree to spend
\$20,000 at your co-op!



2016: Solidarity

Wear Cooperative

has 1000

East Bay members

and \$1,000,000

in collective
buying power!

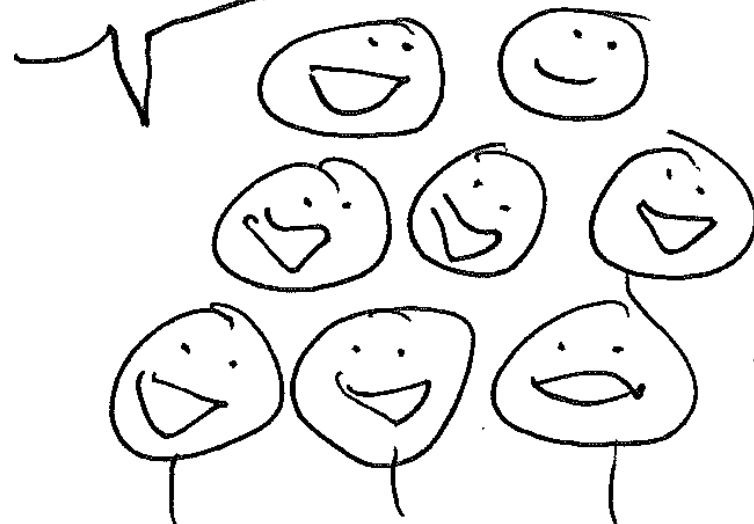

Oakland becomes
a hub of co-op
clothing manufacture



Tailor-
owned
CO-OP

More
CO-ops!

Co-op
Maker
Space

Clothing
Co-op

Worker-
owned
apparel

Worker-
owned
jeans

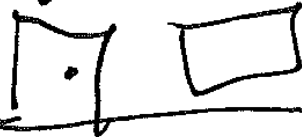

Make *agreements!*

It's community-supported enterprise!

We all agree to
buy one loaf
per week.

- And we agree to:
- Use healthy whole grains
 - Buy from local farmer co-ops
 - Deliver by bicycle, and
 - Pay all worker-owners equal wages

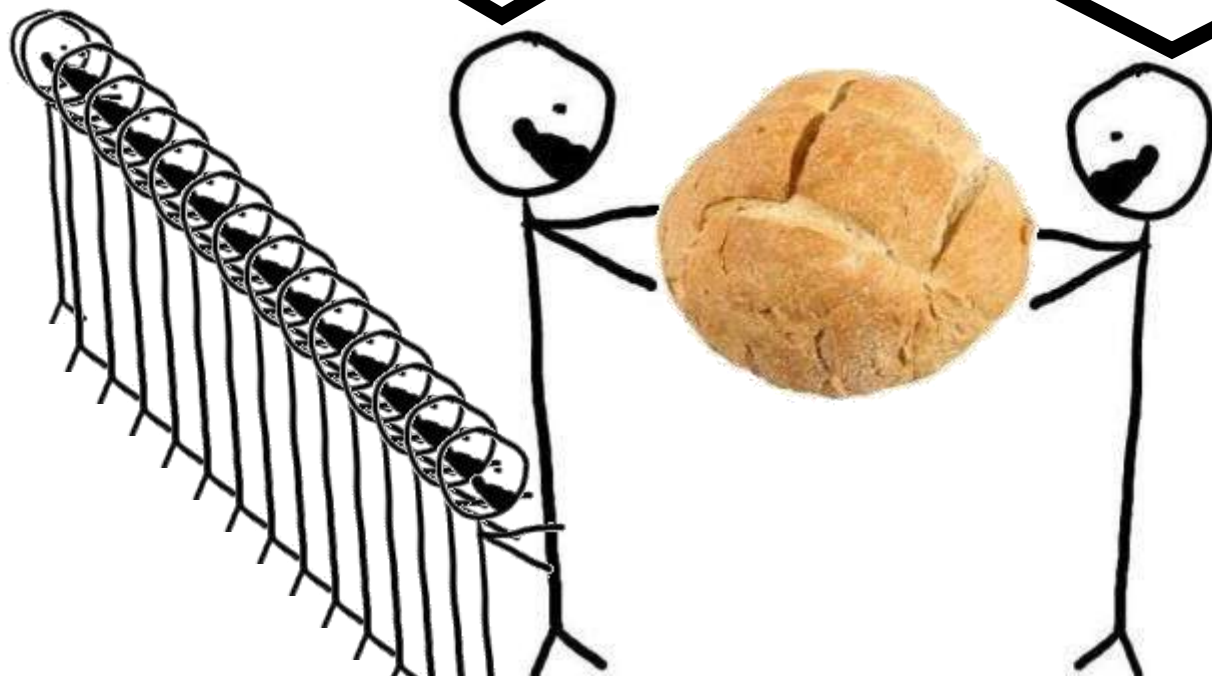

**Our organizations,
themselves,
are creative works!**



What some people
think of nonprofit
organizations....

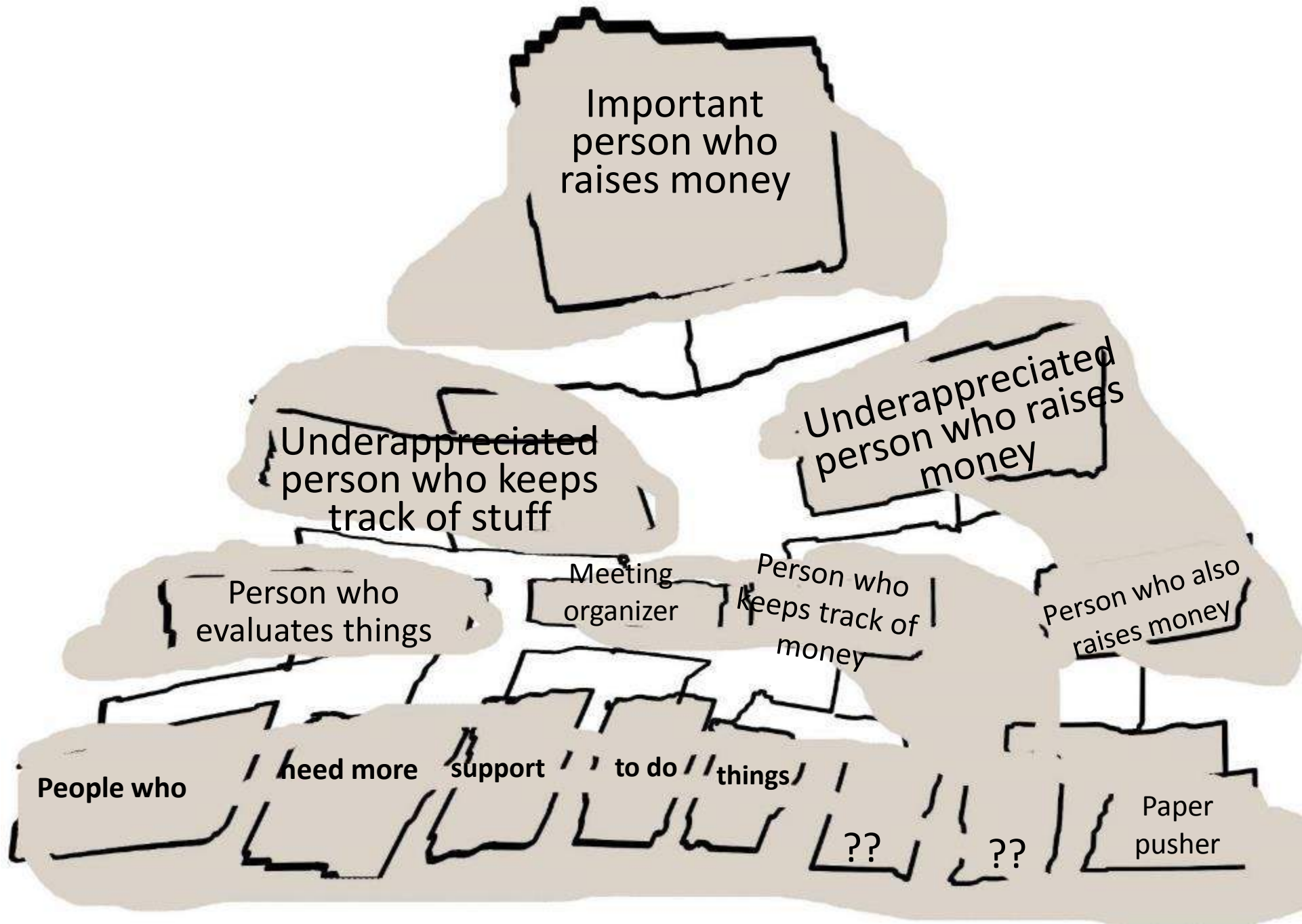

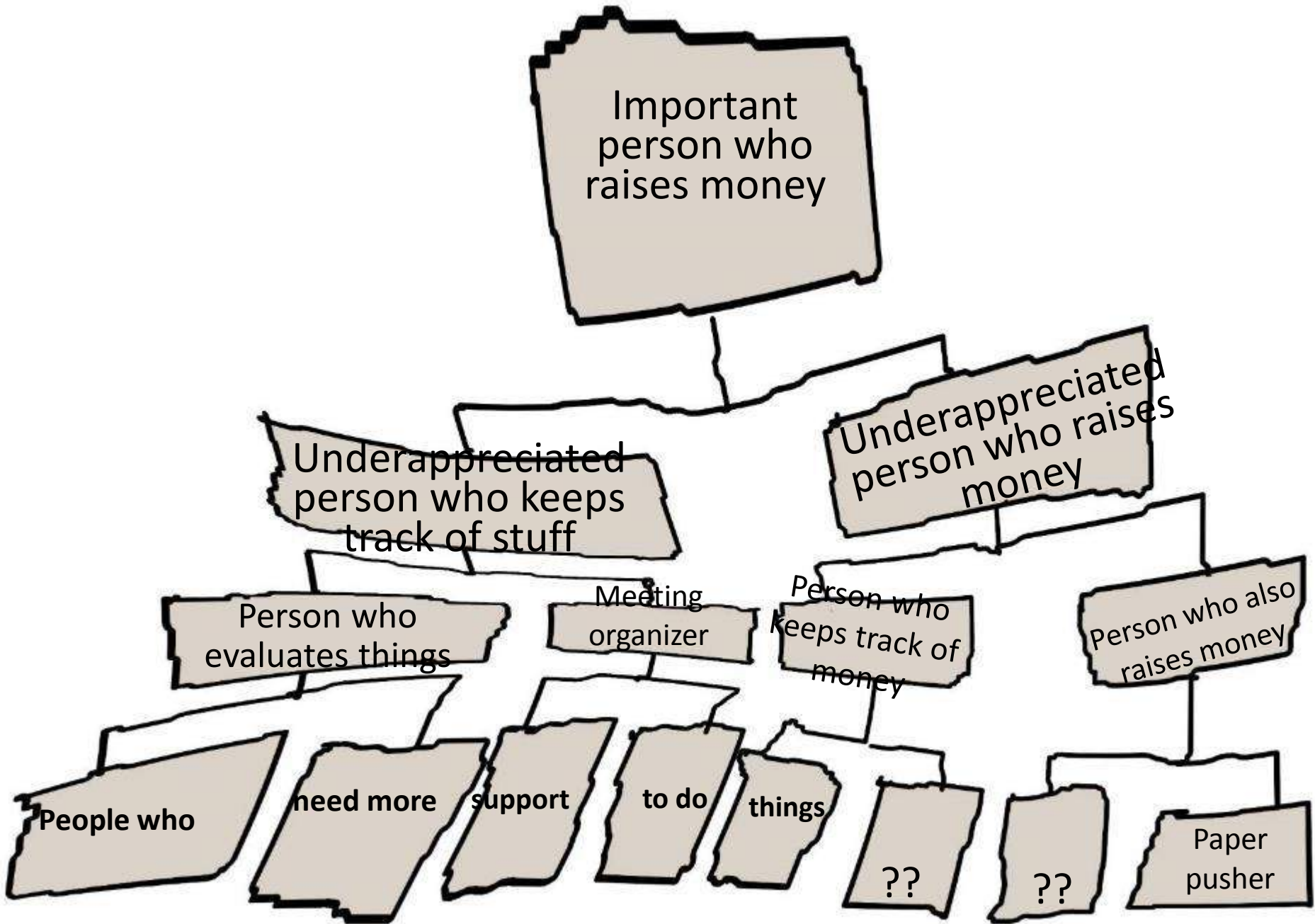

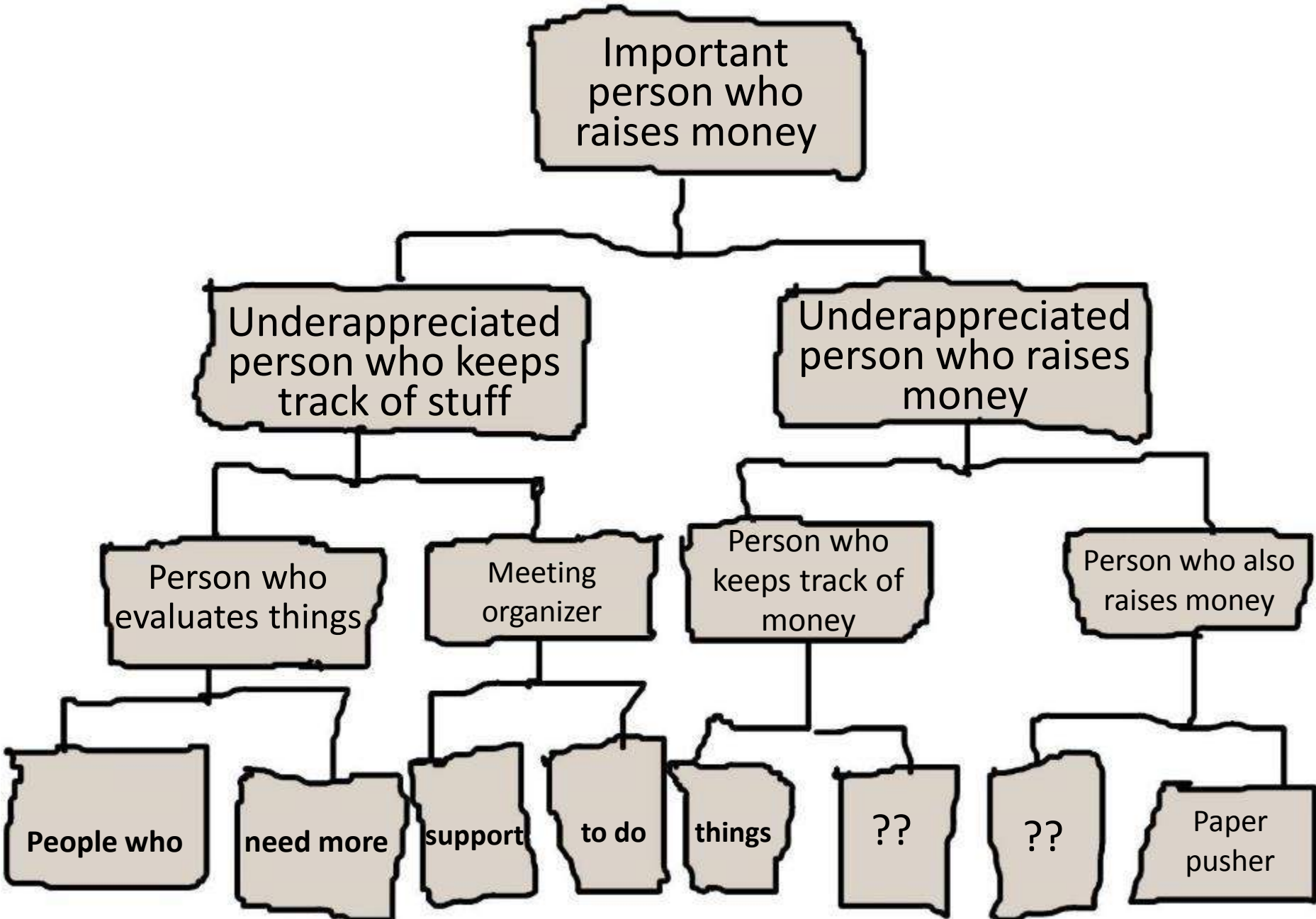

Important person who raises money

Underappreciated person who keeps track of stuff

Underappreciated person who raises money

Person who evaluates things

Meeting organizer

Person who keeps track of money

Person who also raises money

People who

need more

support

to do

things

??

??

Paper pusher



Sustainable
Economies
Law Center

and holacracy!
(More info at www.holacracy.org)



What does worker self-direction mean?

Here's one crack at a definition:

- **All workers** have power to influence:
 - The realms and programs in which they work,
 - The conditions of their workplace,
 - Their own career paths, and
 - The direction of the organization as a whole.
- The organization's goals, strategies, and activities emerge primarily from the observations, experiences, insights, proposals, and decisions of workers throughout the organization.

Important:

It's not that every decision needs to be made by everyone.



Polycentricity

English-to-English Translations
Many Centers of Power

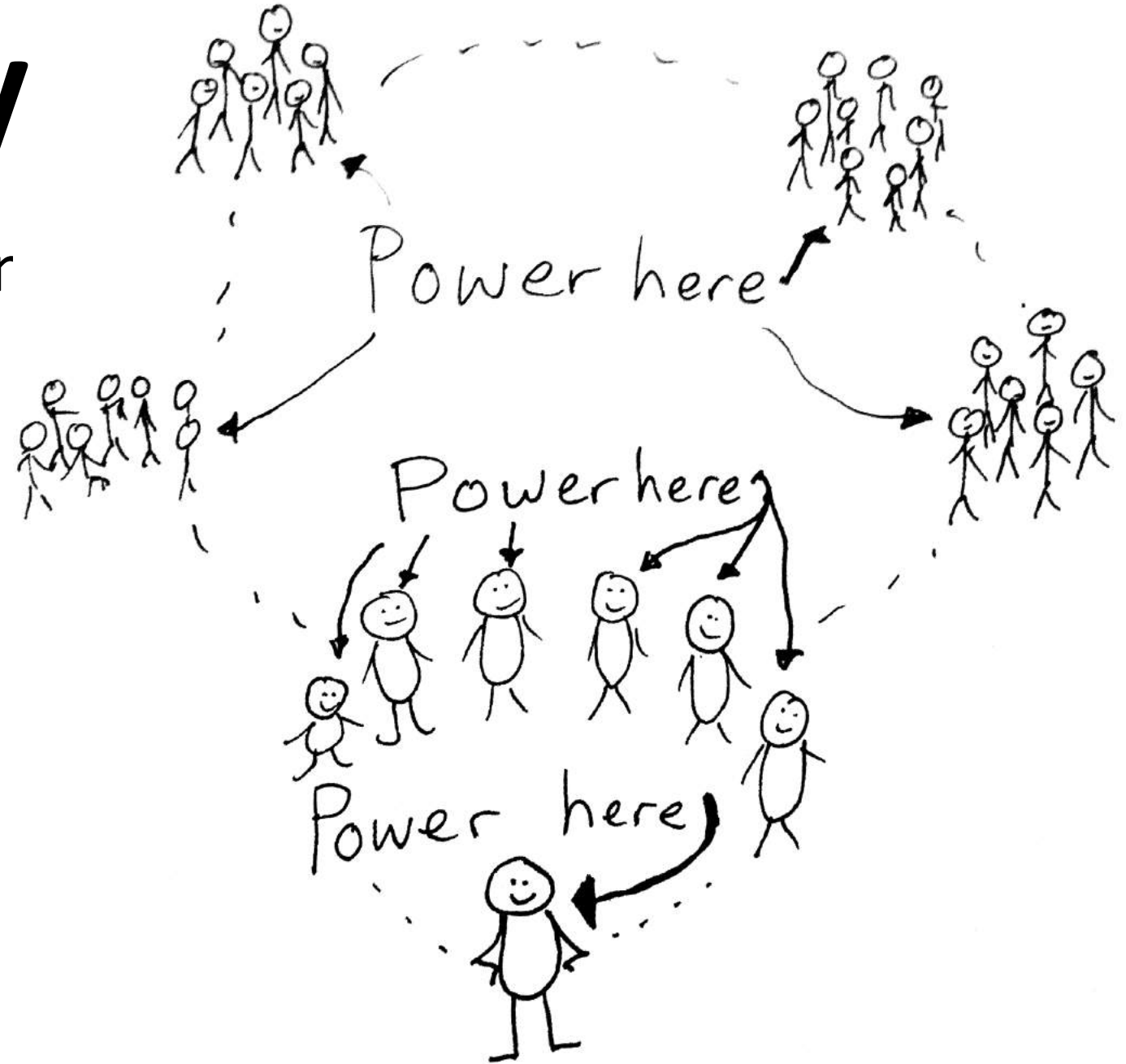

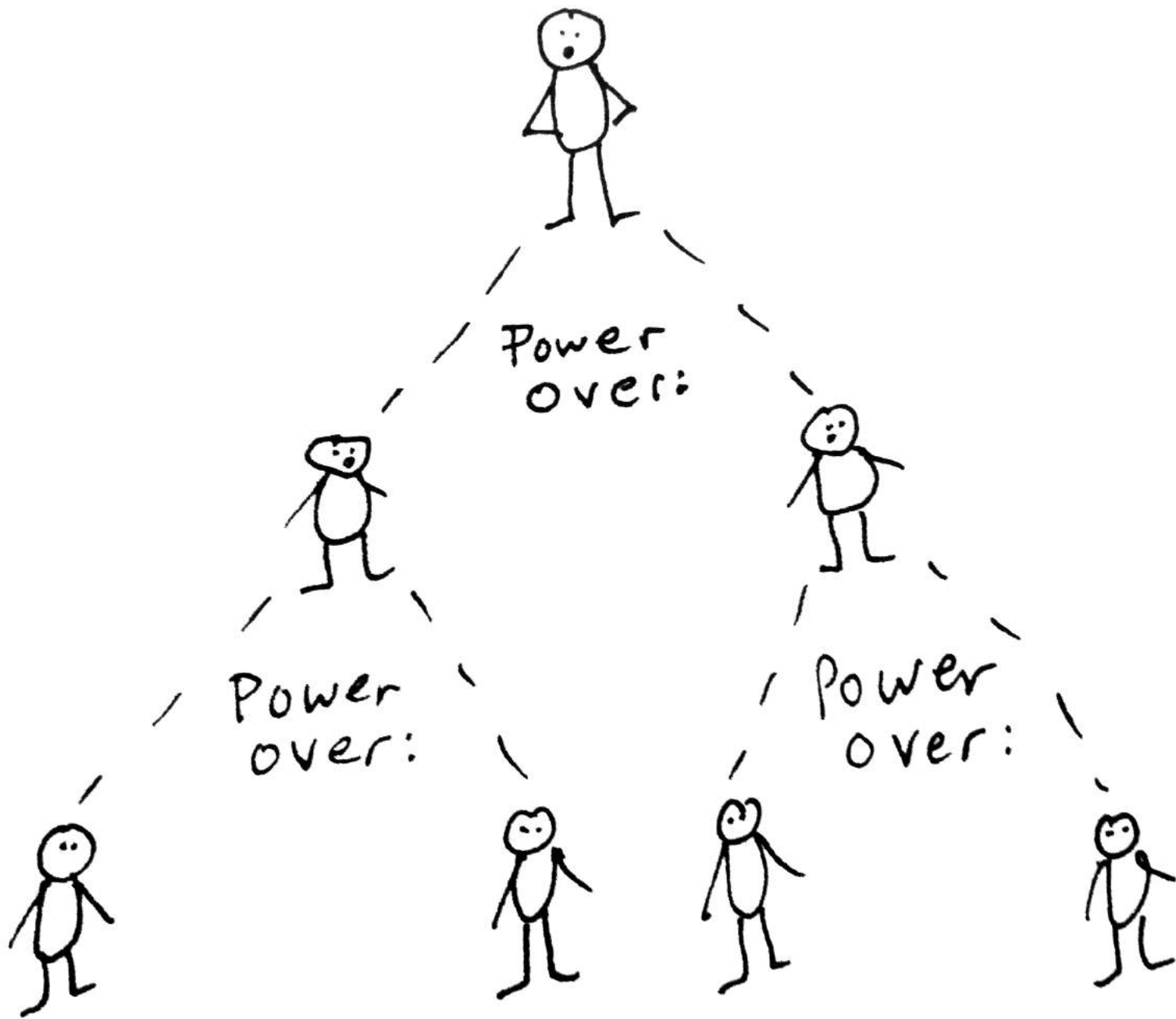

What motivates people to work in the arts or social change sectors?

I can make three times as much money as the average person!

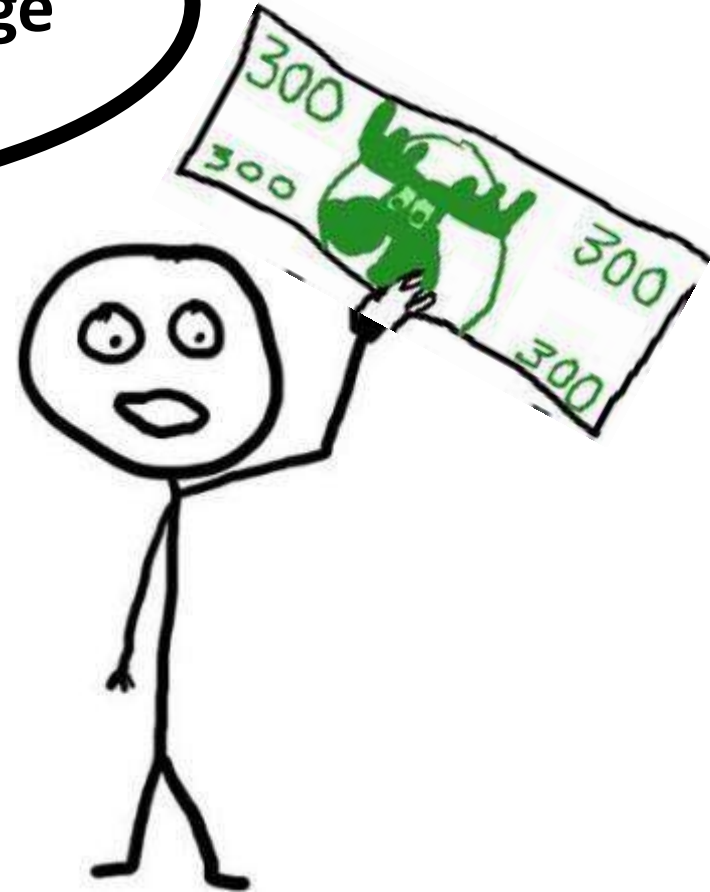

I want **satisfying work**, in a place where **my voice matters**, I have **control** over my work, I **learn and grow**, I can use my **creativity**, build **community**, advance **equity**, and have **fun!**

Best
accomplished
through worker
self-direction!



**Everyone is
behind a wheel!**



F R E D E R I C L A L O U X

FOREWORD BY KEN WILBER

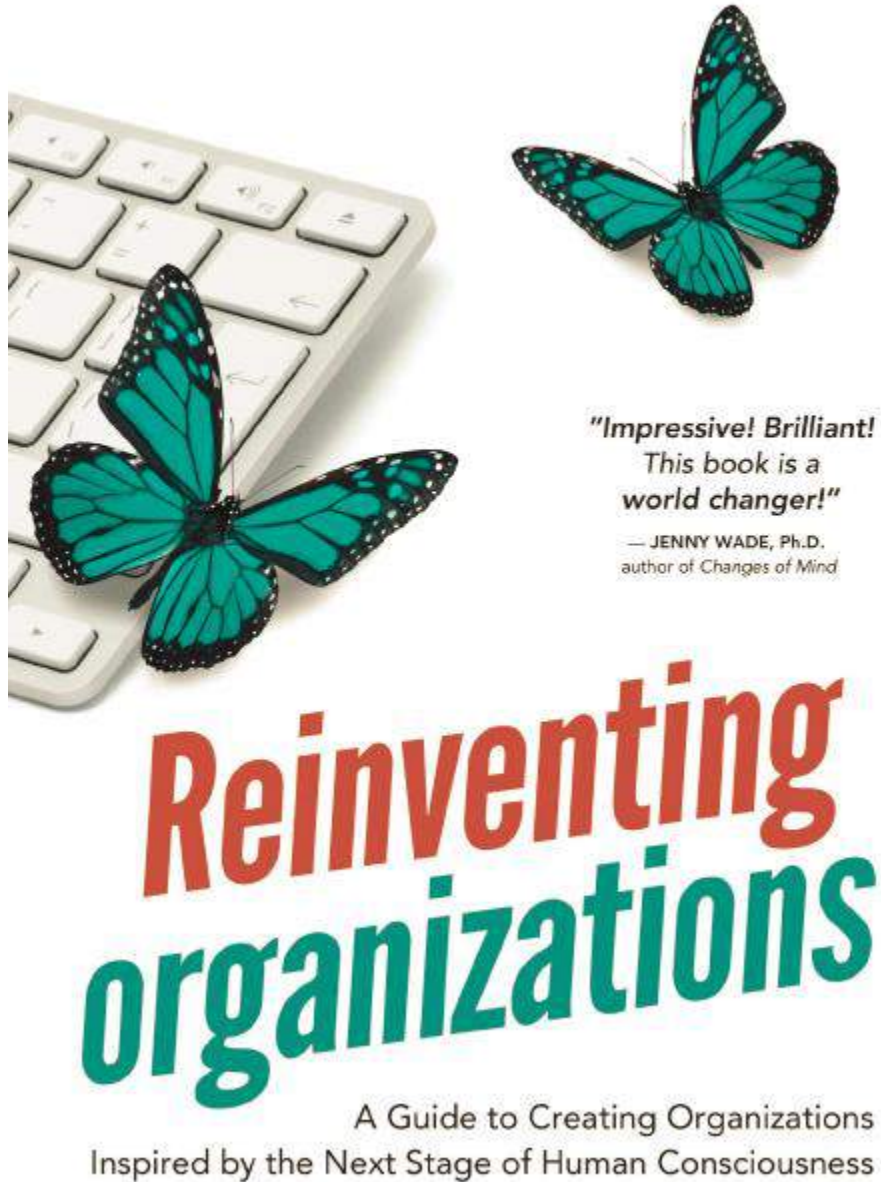

Read *Reinventing Organizations*,
By Frederic Laloux

GOOD BOOK!



En serio, todas las Socias deben participar en el manejo de la Cooperativa

Para promover una cultura en la que todas las Socias están motivadas y animadas a participar en la gestión de la Cooperativa, cada Socia puede – y debe – proponer políticas y actividades para mejorar el funcionamiento de la Cooperativa.

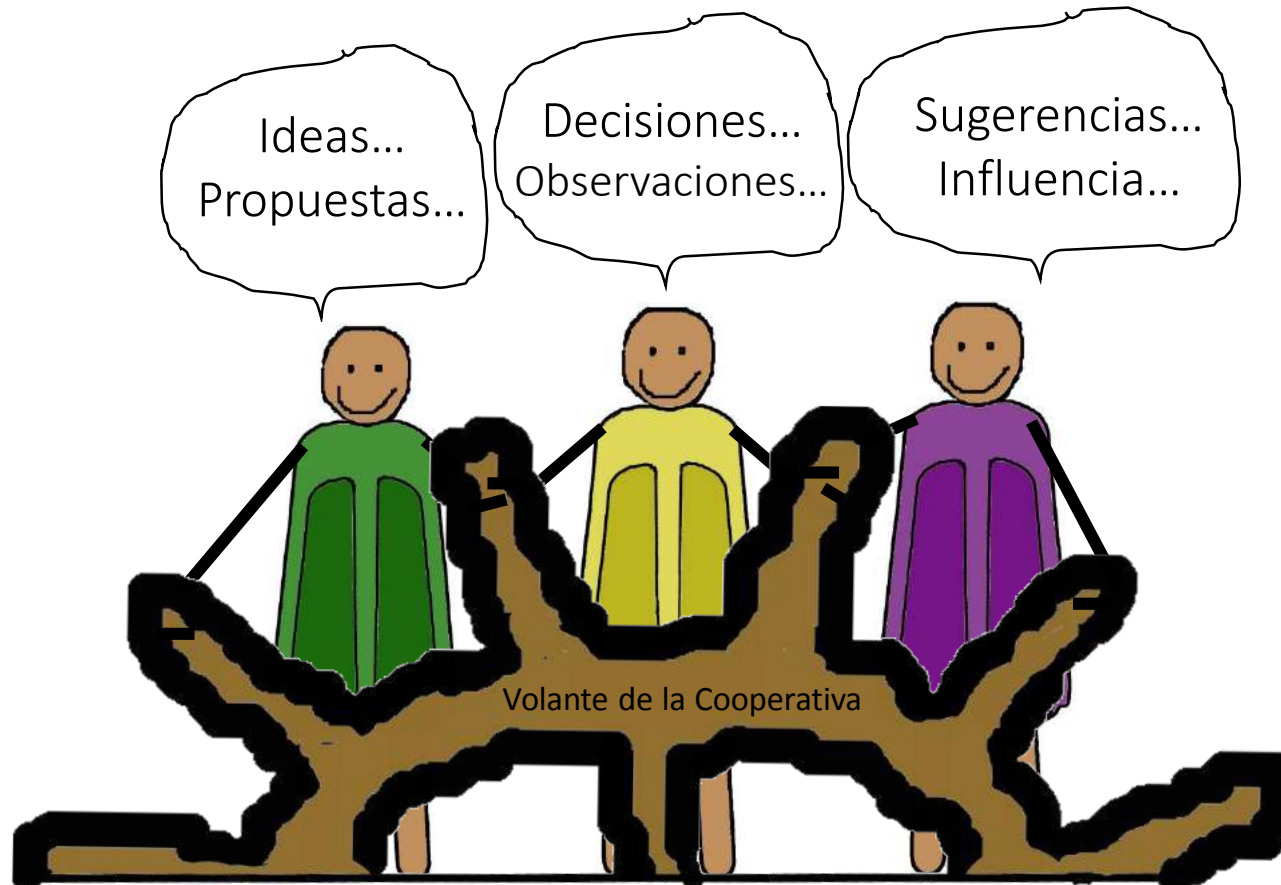

Y cada Socia debería tener influencia en los siguientes dominios:

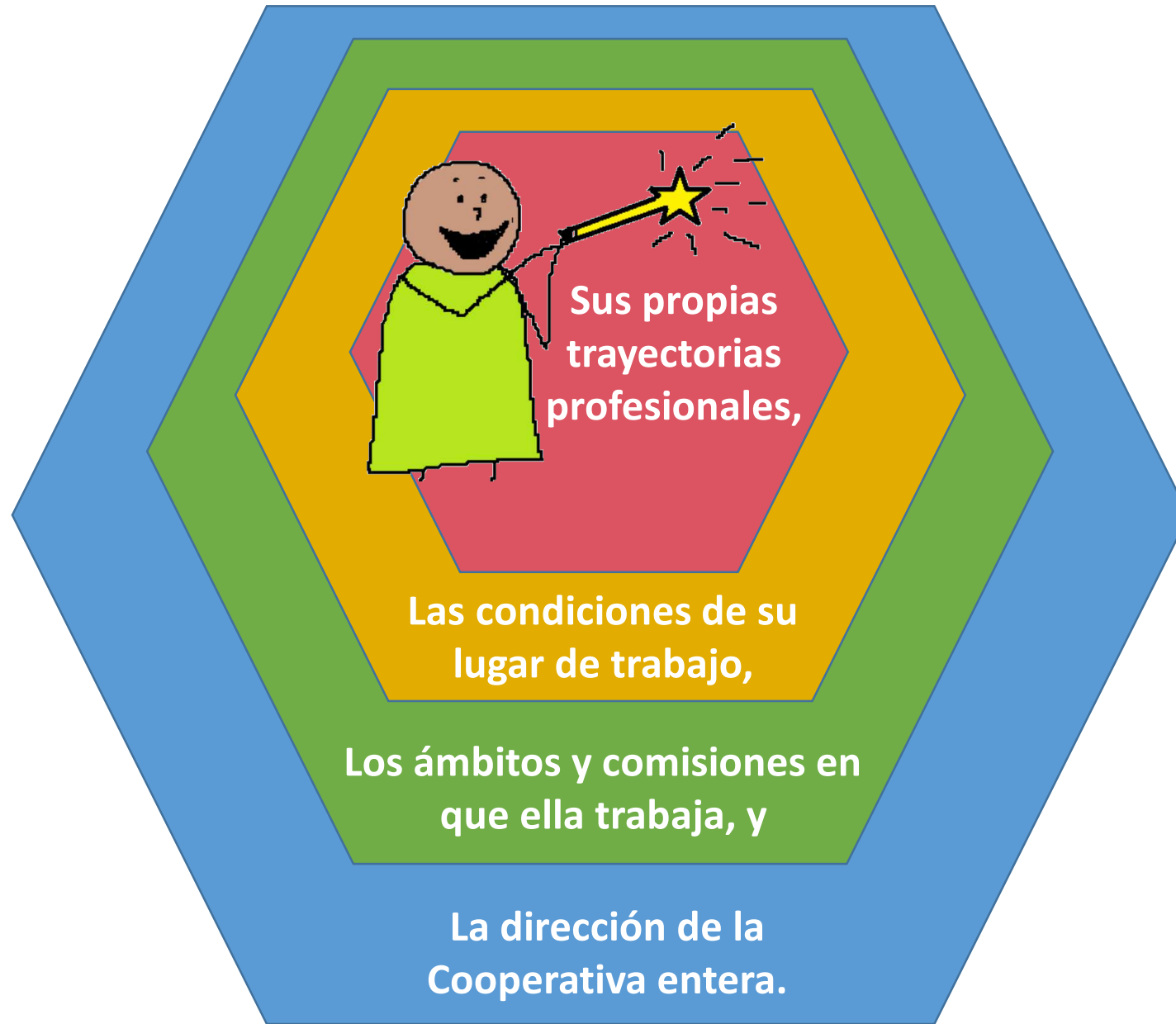

La rotación de responsabilidades

Con el fin de empoderar a todas las Socias comprender varios aspectos de la empresa, y con el fin de evitar que se formen jerarquías, las Socias rotarán regularmente las responsabilidades. Cada Socia puede desarrollar un área particular de la habilidad y responsabilidad, pero al mismo tiempo, también se compromete a entrenar otras Socias en esa área.

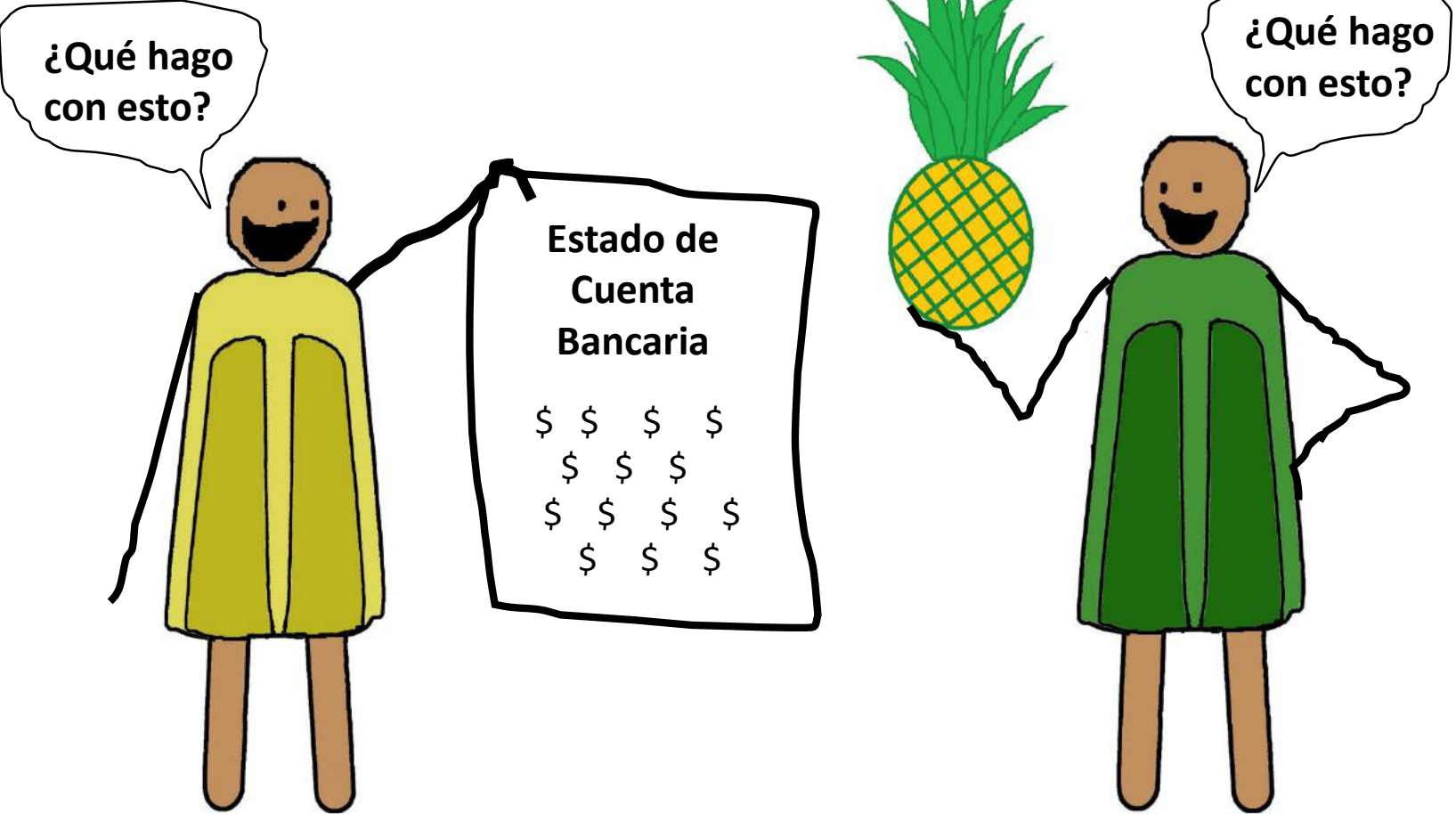

Cada Socia va a crear y ejecutar su plan de desarrollo para aprender como administrar a la compañía y también un plan de desarrollo personal. Por ejemplo:

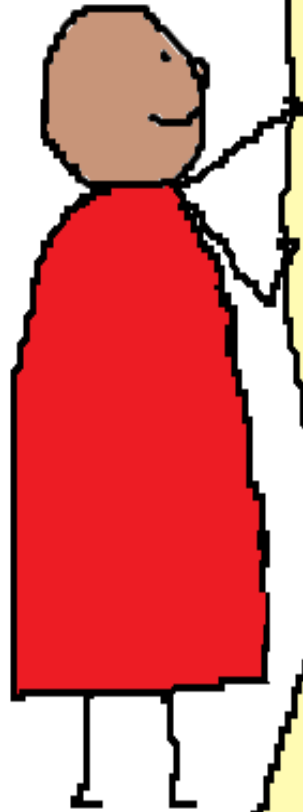

El camino de mis primeras 12 meses. Aprender de:

- Planificación de empresas
- Administración y mantenimiento de registros
- Licencias y seguros
- Contabilidad básica
- Ventas y mercadotecnia
- Compras y suministros
- La producción de paletas
- La facilitación de reuniones
- Resolución de conflictos
- Fiesta para celebrar lo que he aprendido!



La división de responsabilidad y creación de comisiones

Todas las Socias se reunirán regularmente para gestionar en general la Cooperativa.

Cuando sea posible, las Socias repartirán las responsabilidades en comisiones. Ejemplos de comisiones posibles incluyen:

Un objetivo de dividir a la Cooperativa en comisiones es dar a cada Socia cierta **autonomía** en sus propios ámbitos de trabajo. Otro objetivo importante de la Cooperativa es **tomar decisiones de manera eficiente**. Por lo tanto, muchas de las decisiones se pueden hacer fuera de grupo entero de Socias. **Una lista actual de las comisiones y sus funciones se encuentra en otro documento como las “Políticas, Procesos, y Funciones.”**

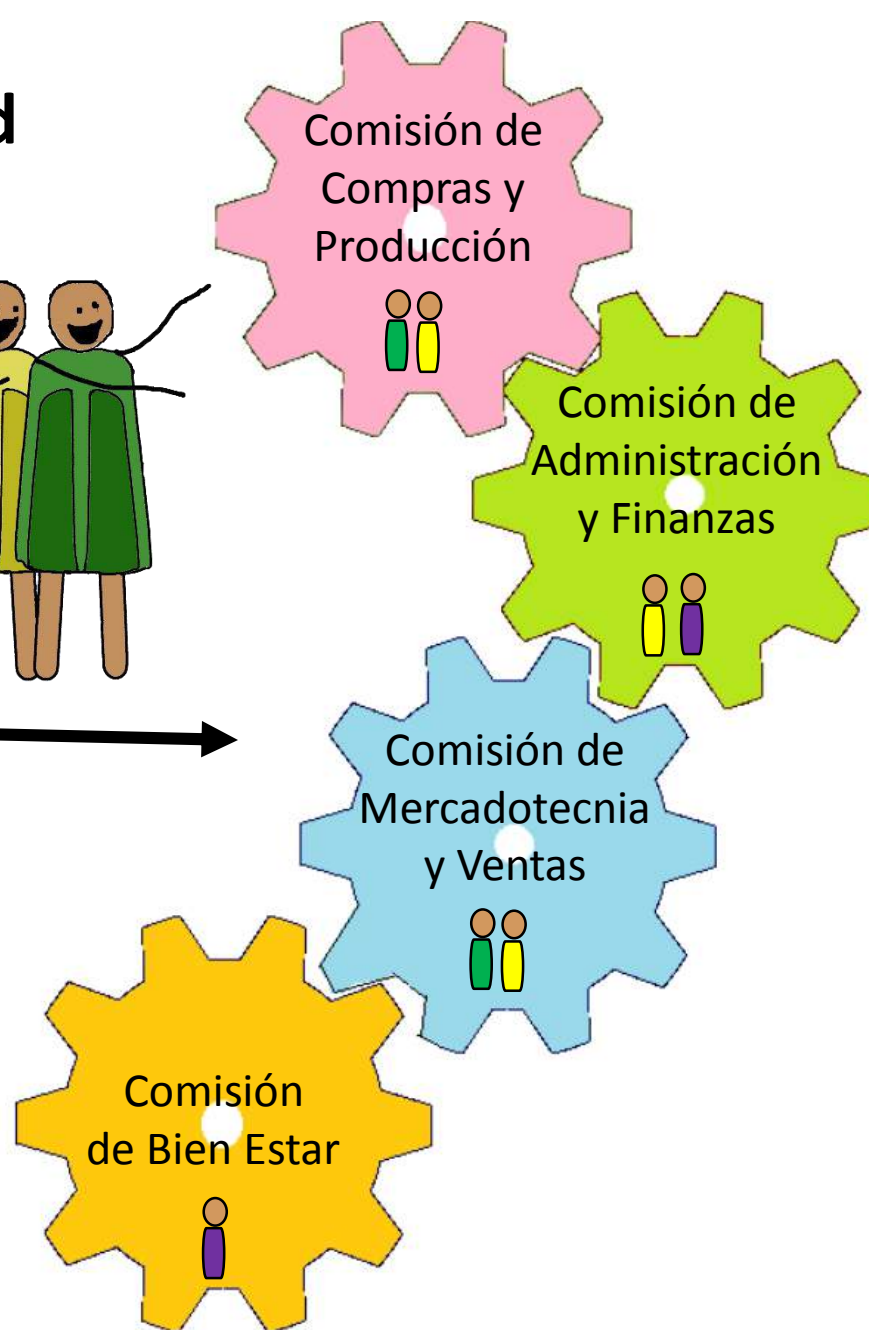
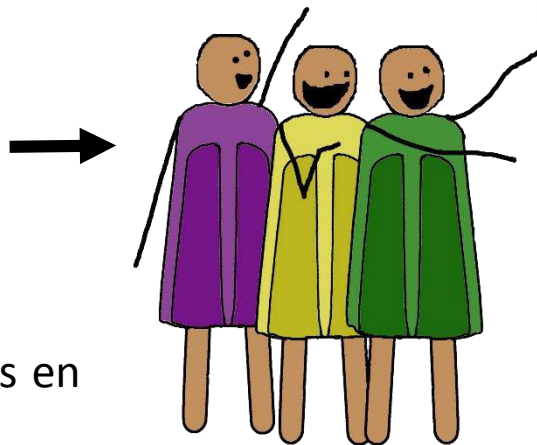

El proceso de las reuniones:

En general, todas las propuestas y asuntos estarán discutidos haciendo que las Socias hablan uno por uno, sigiente en un círculo. De esta manera, cada Socia tendrá la oportunidad de hablar y de influir en las decisiones. La facilitadora dará la vuelta varias veces para que las Socias no se sienten que deben decir todo lo que se les ocurren la primera vuelta.



Mantenimiento de registros, información, y contabilidad



The image shows a screenshot of a Box file sharing interface. On the left, there is a sidebar with a list of folders, each with a folder icon and a right-pointing arrow. The folders are:

- Acuerdo de Operaciones**
La versión más actualizada y versiones anteriores
- Políticas y Reglas**
Cualquier regla adoptada por las Socias fuera de este Acuerdo.
- Información Financiera**
Declaraciones de pérdidas y ganancias, hojas de saldo, estados de cuenta bancario
- Declaraciones de Impuestos**
- Reuniones**
Actas de Reuniones
- Socias**
Una lista de todas las Socias y ex-Socias, sus direcciones, teléfonos, etc.
- Registros de Trabajo**
¿Cuánto ha trabajado cada Socia (y ex Socia) durante cada mes y cada año?
- Licencias**
Y otros papels presentados al estado, condado, y ciudad
- Misceláneo**

On the right side of the interface, there is a large light blue area containing text and an illustration. The text reads:

La Cooperativa siempre estará obligada a mantener registros de, por lo menos, los que se enumeran aquí a la izquierda. Los registros deben vivir en un lugar que sea accesible a todas las Socias, como en una plataforma como Box o Dropbox, o en una carpeta física a que cada Socia tiene acceso.

Below the text is an illustration of a person with a brown head and a green shirt sitting at a black laptop. A white thought bubble above the person contains the text:

La información que necesito para tomar decisiones está aquí, todo en un solo lugar! Estamos tan organizadas!

The interface also features a blue header with the 'box' logo, a search icon, and navigation icons (+, up arrow, and menu). At the bottom, there is a dark navigation bar with icons for back, home, and folder.

**Let's gamify the
cooperative
revolution!**

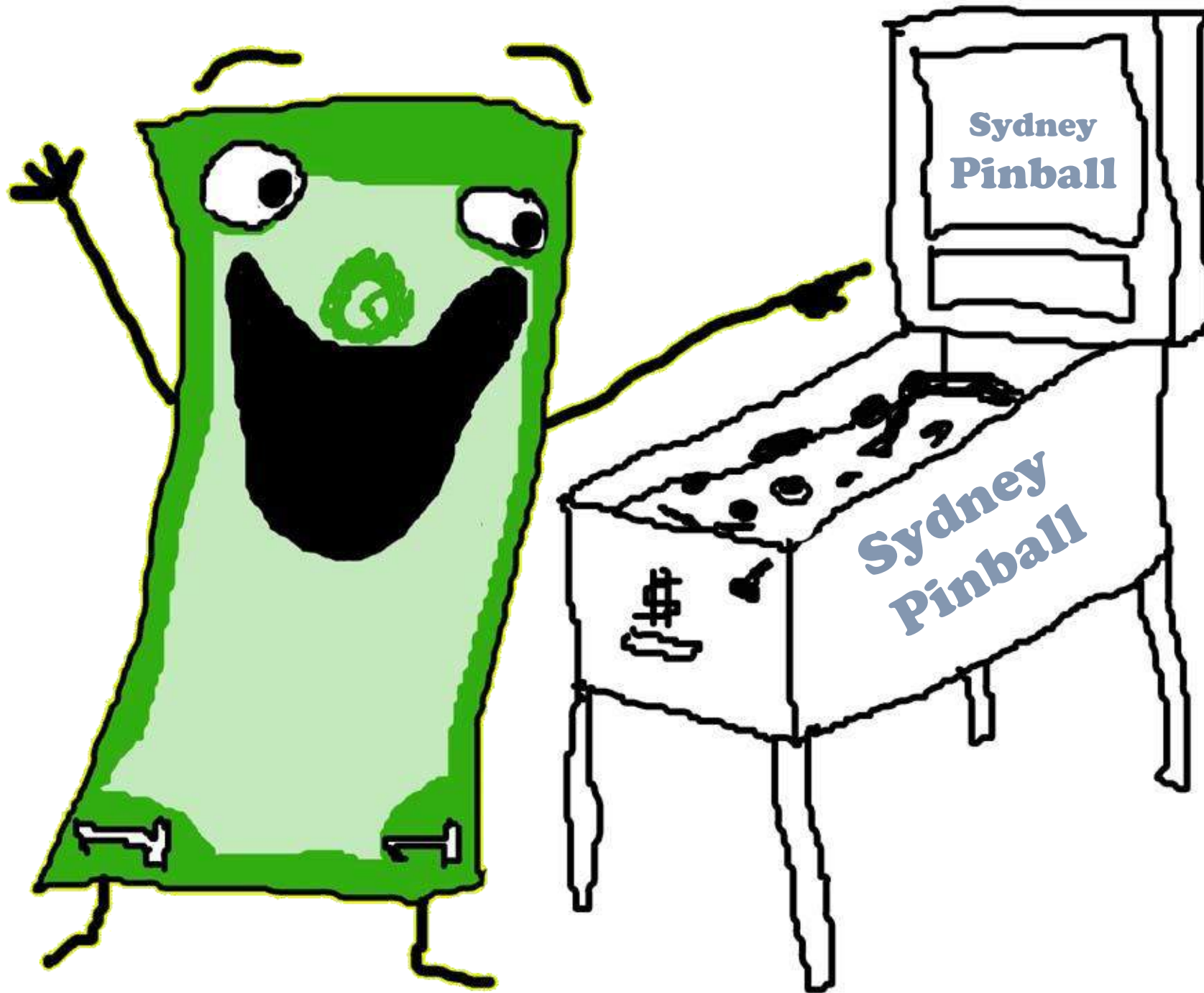



Your Score
(i.e. your local wealth)

\$1.00

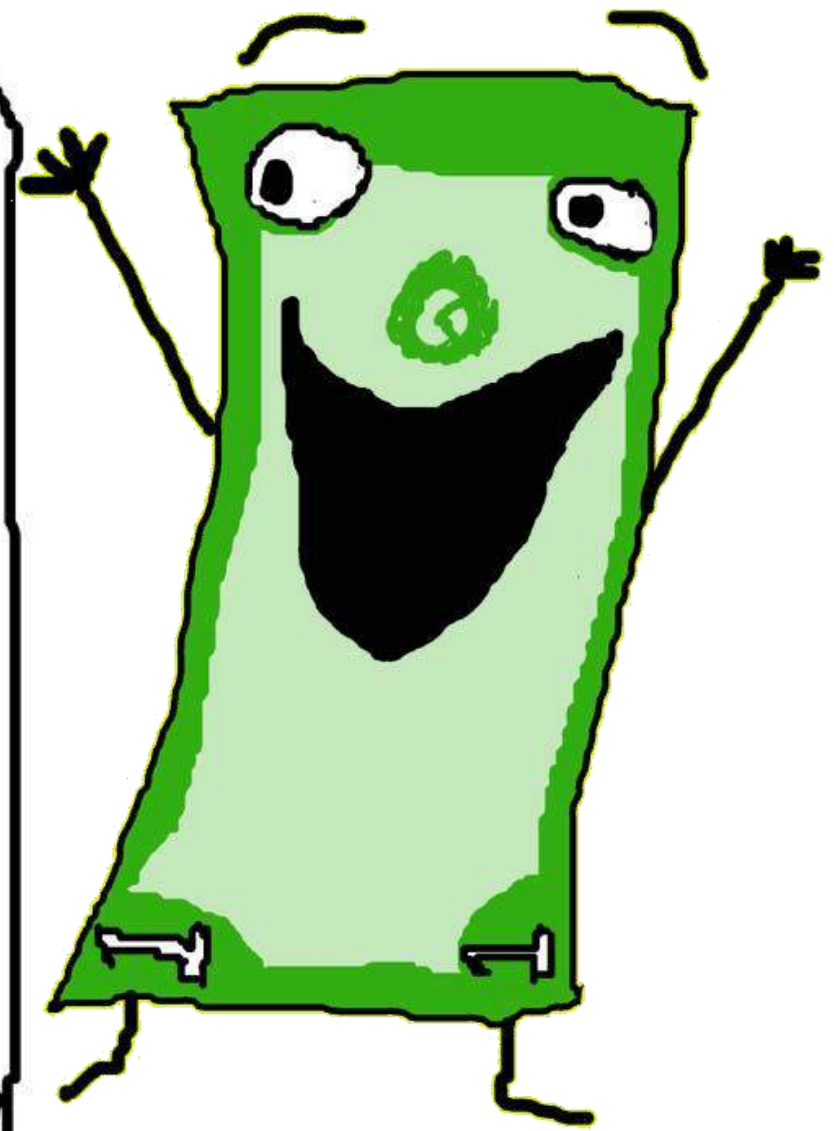
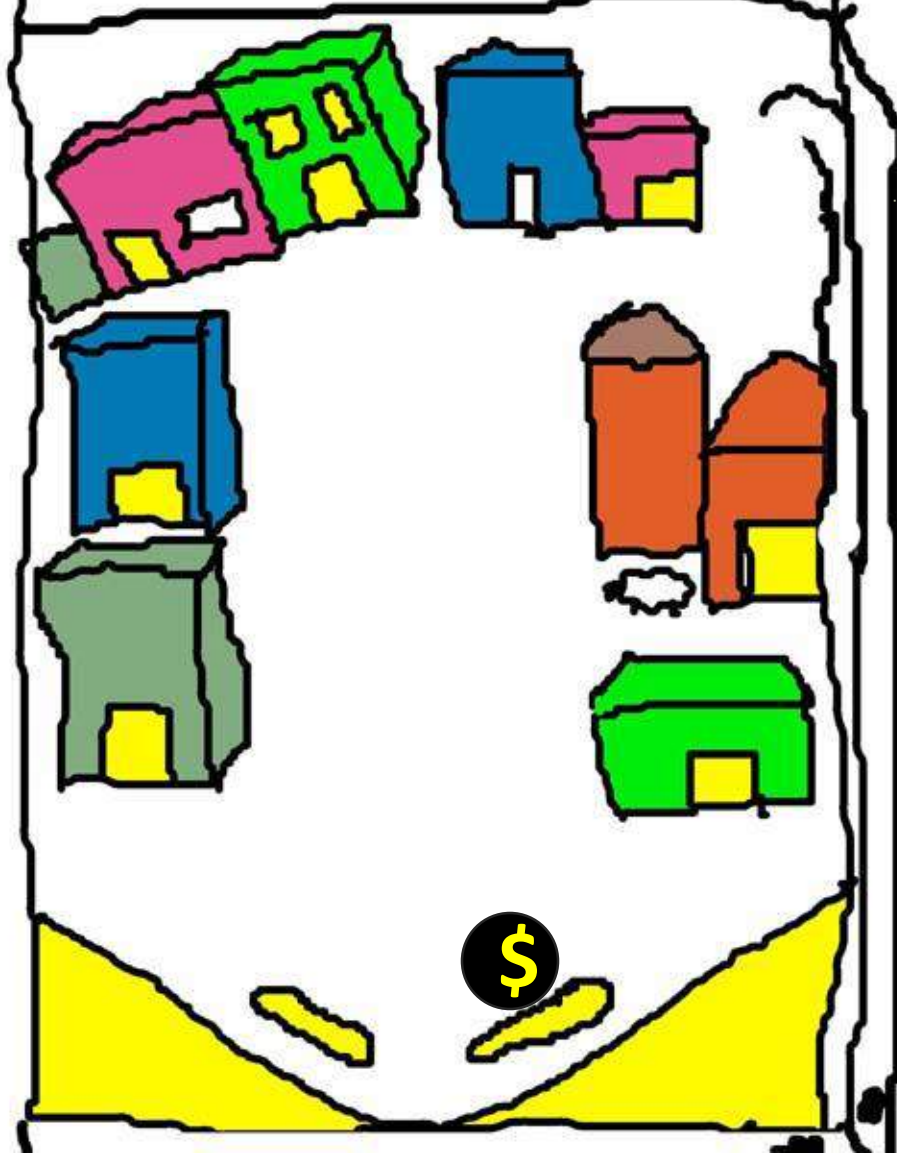

Your Score
(i.e. your local wealth)

\$2.00

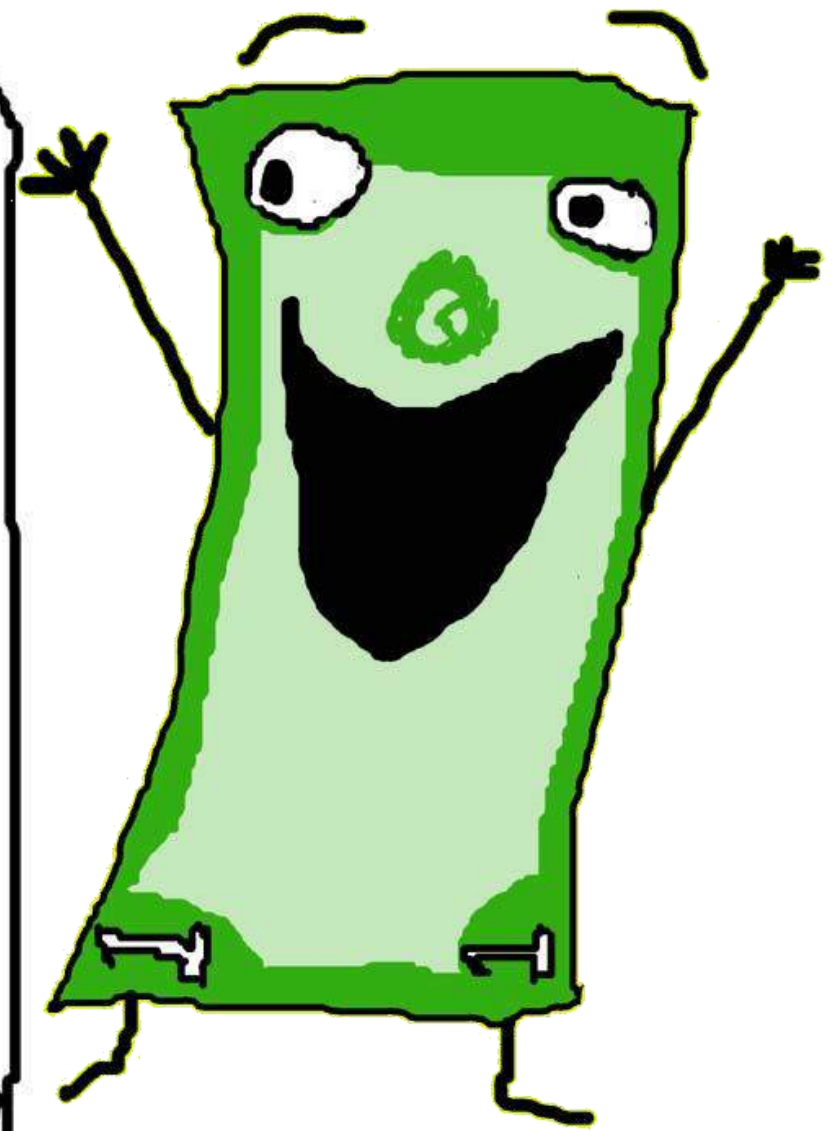
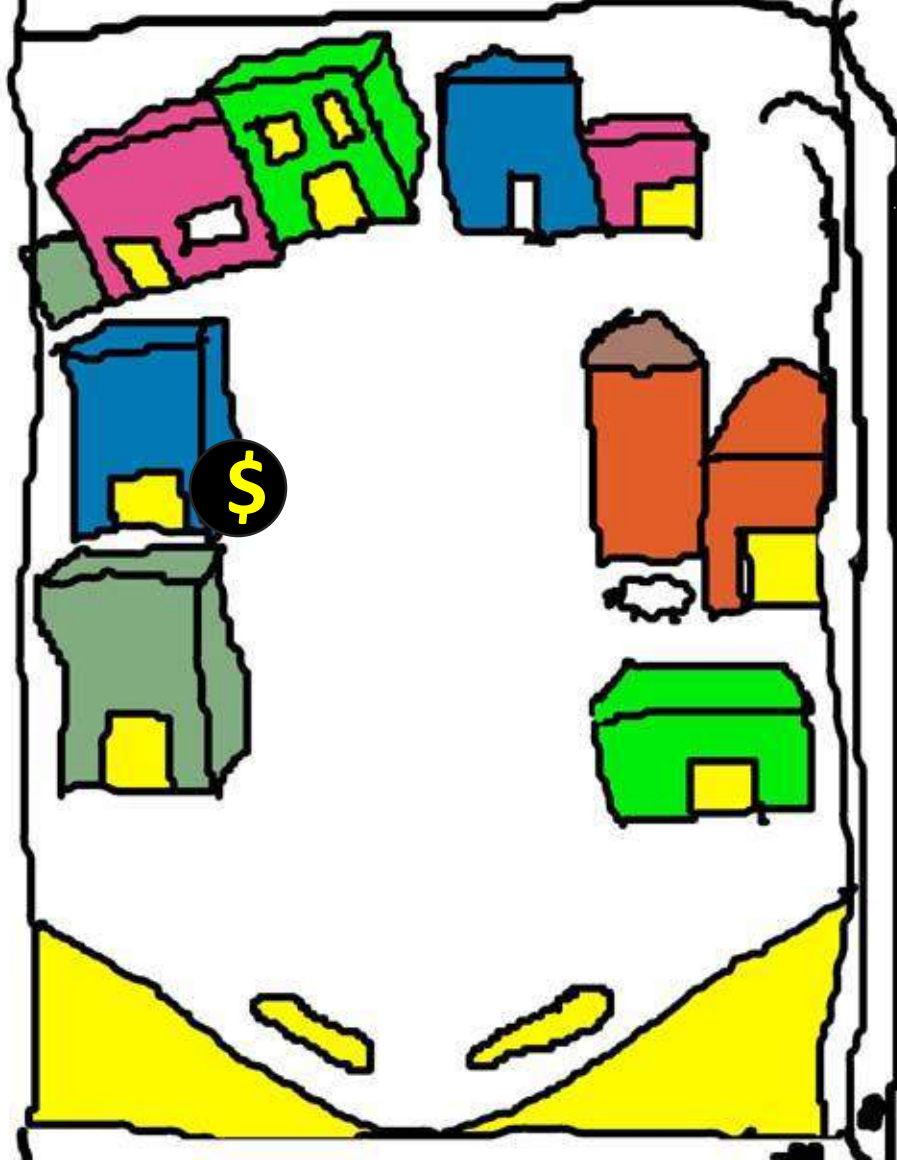

Your Score
(i.e. your local wealth)

\$3.00

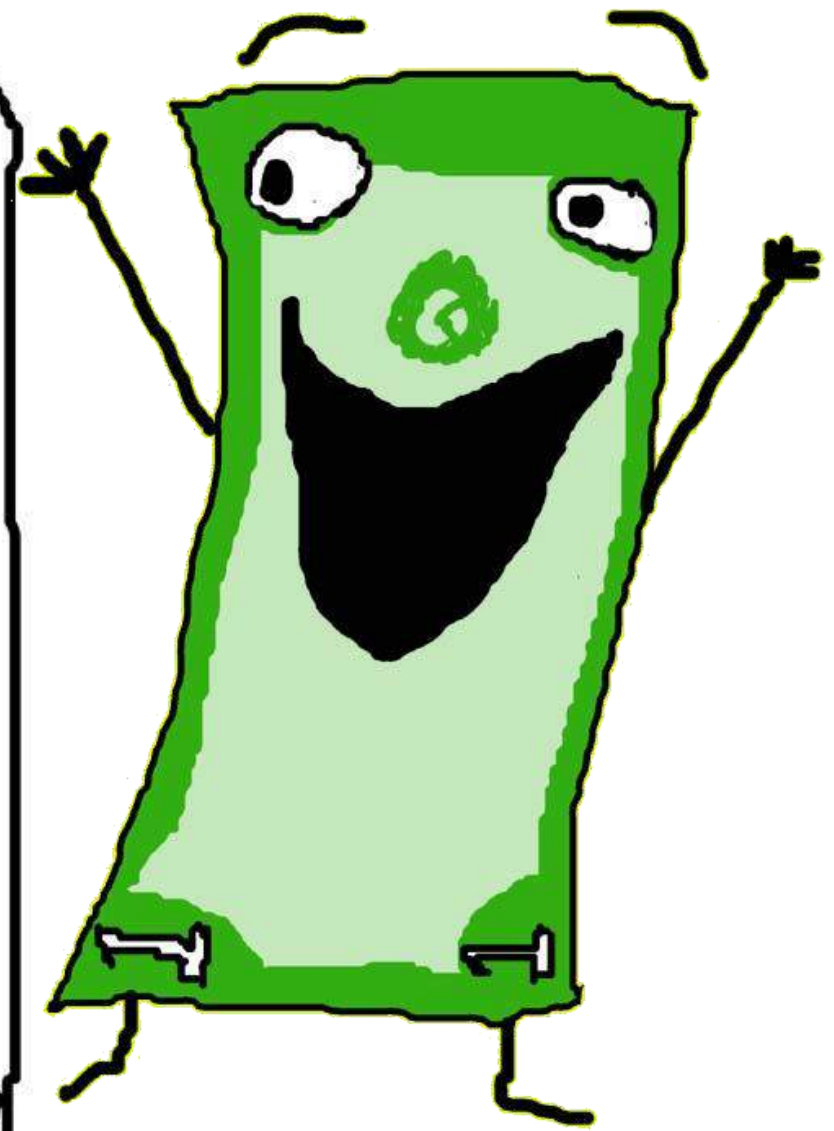
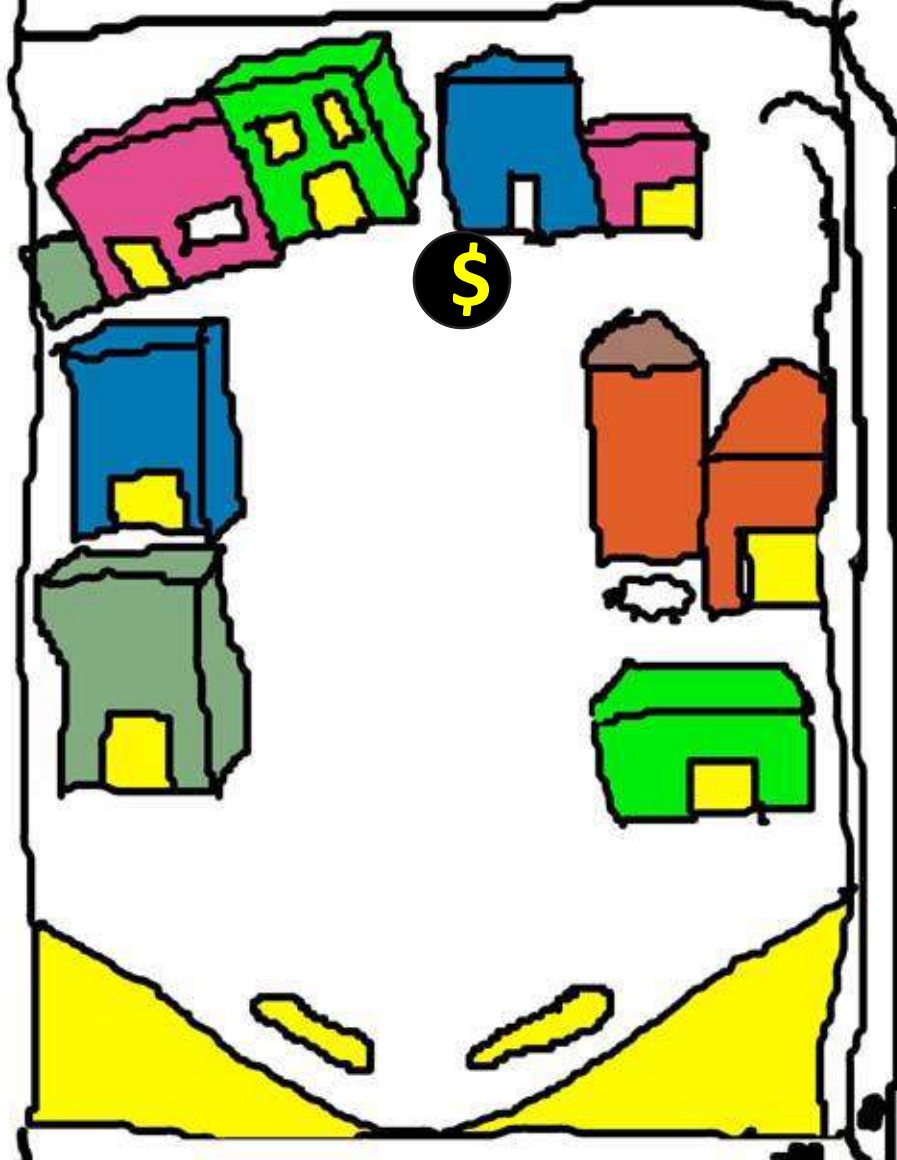

Your Score
(i.e. your local wealth)

\$4.00

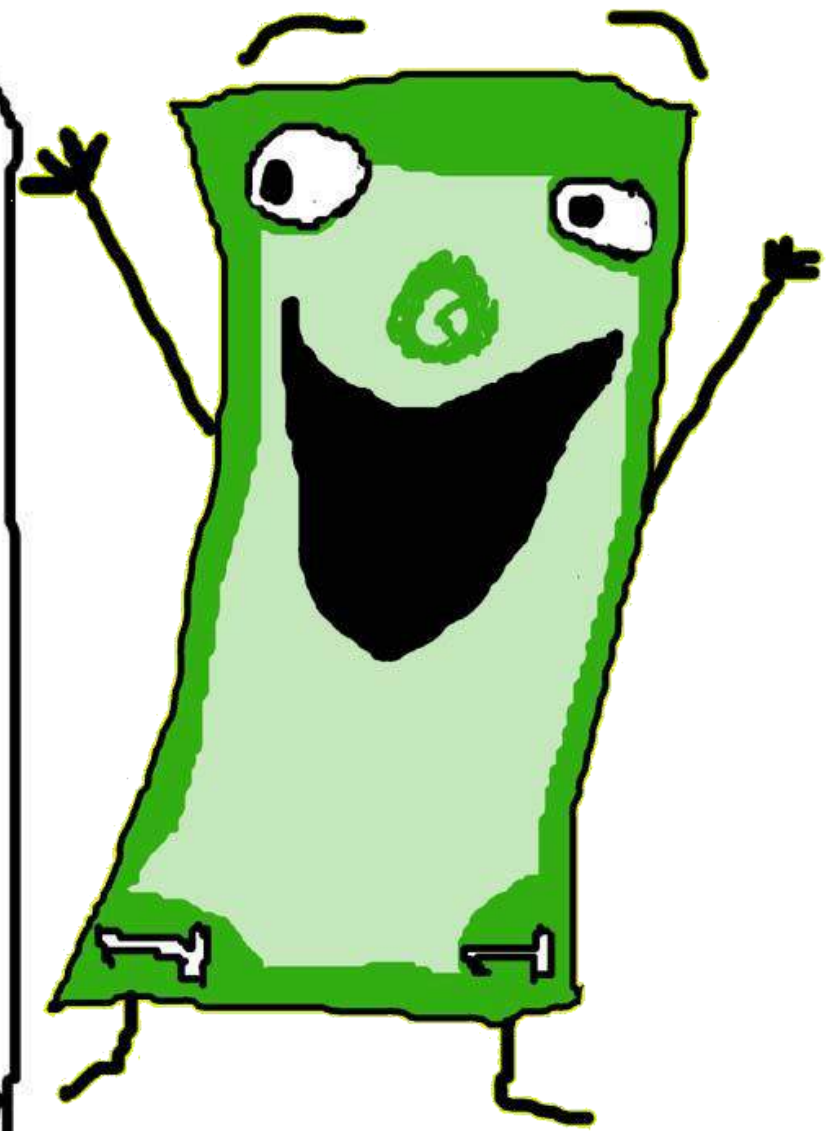
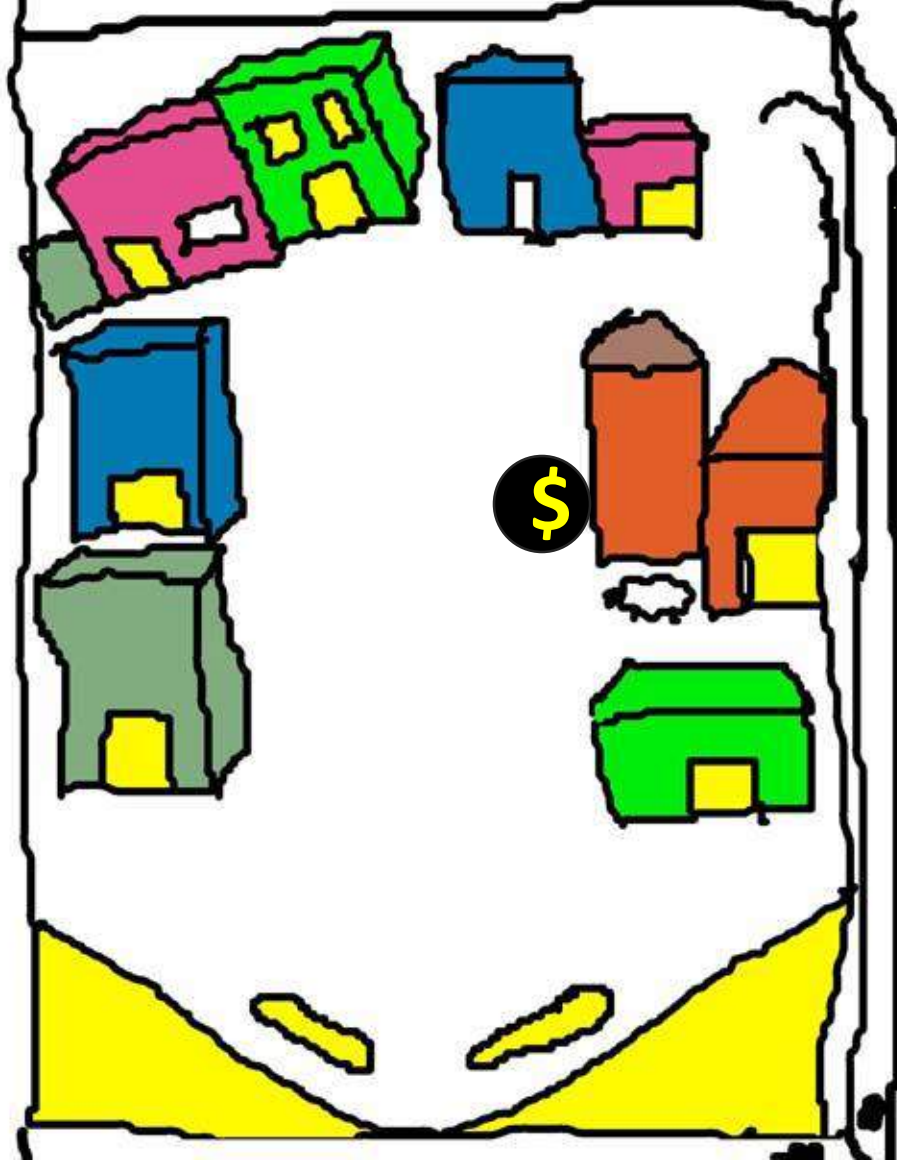

Your Score
(i.e. your local wealth)

\$5.00

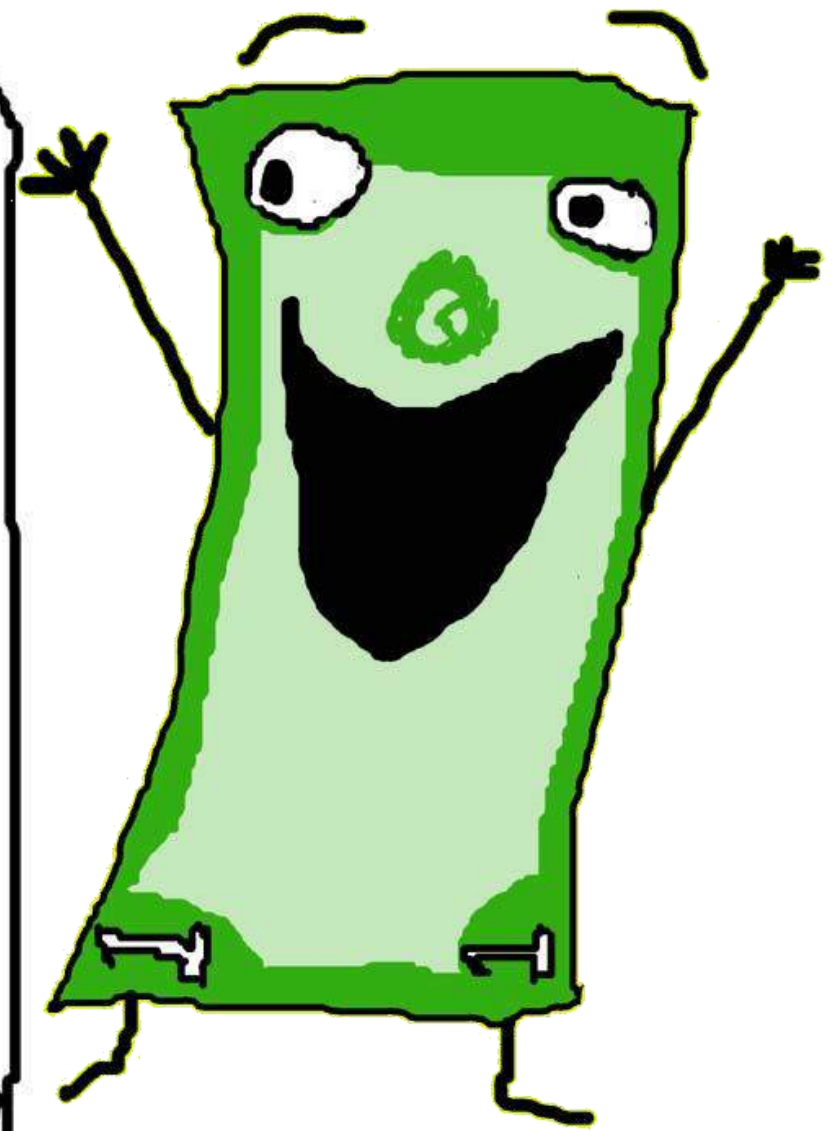
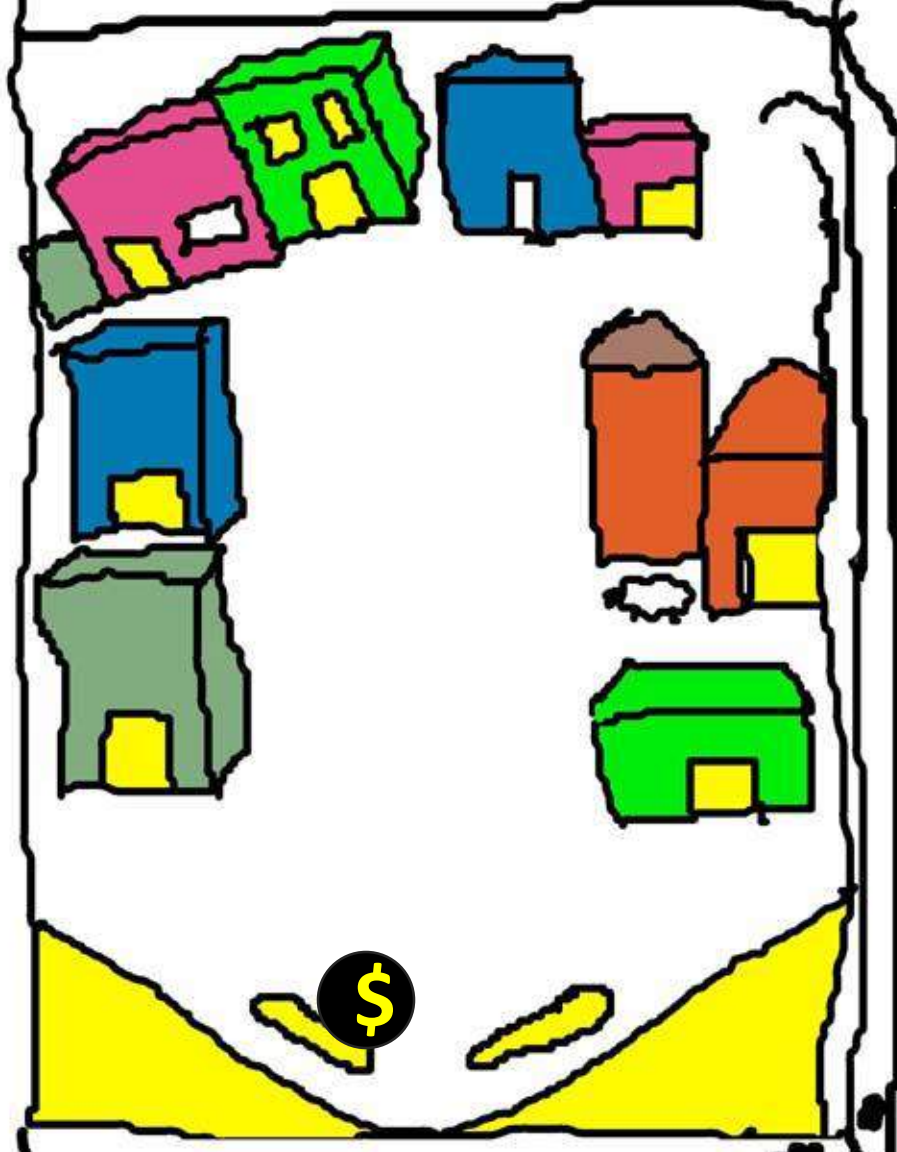

Your Score
(i.e. your local wealth)
\$1000.00

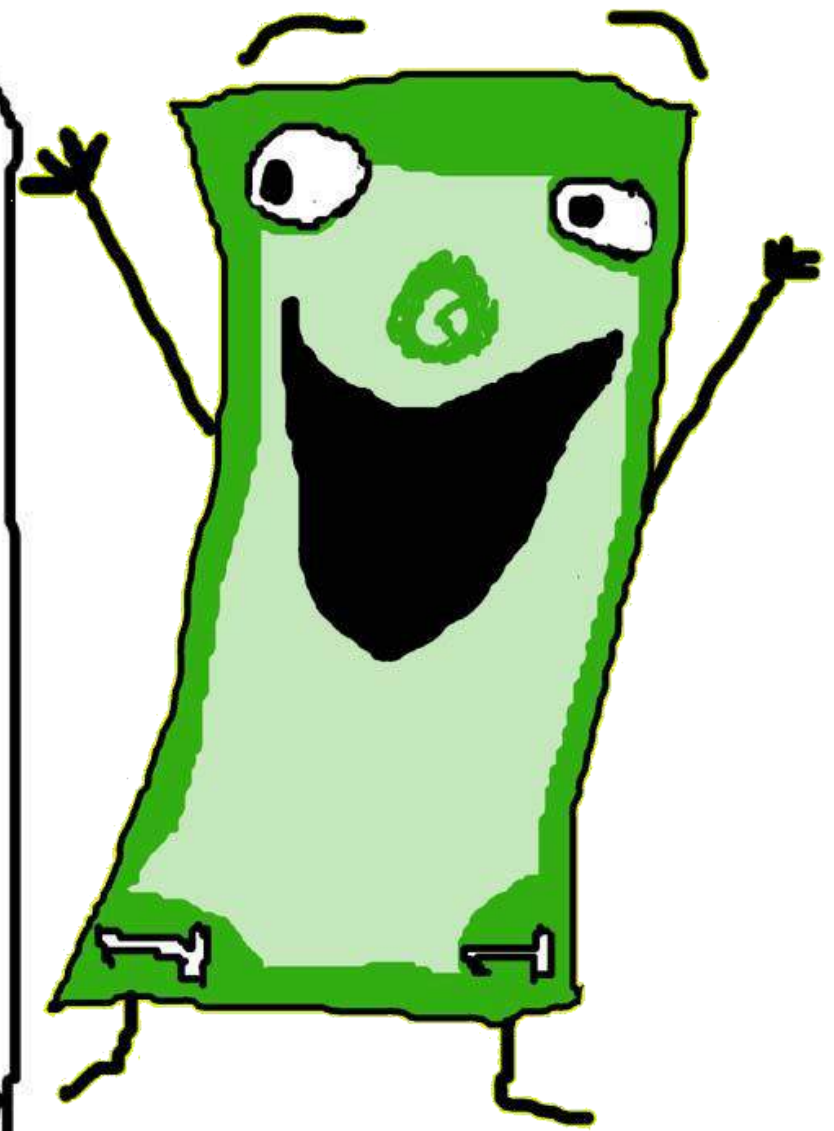
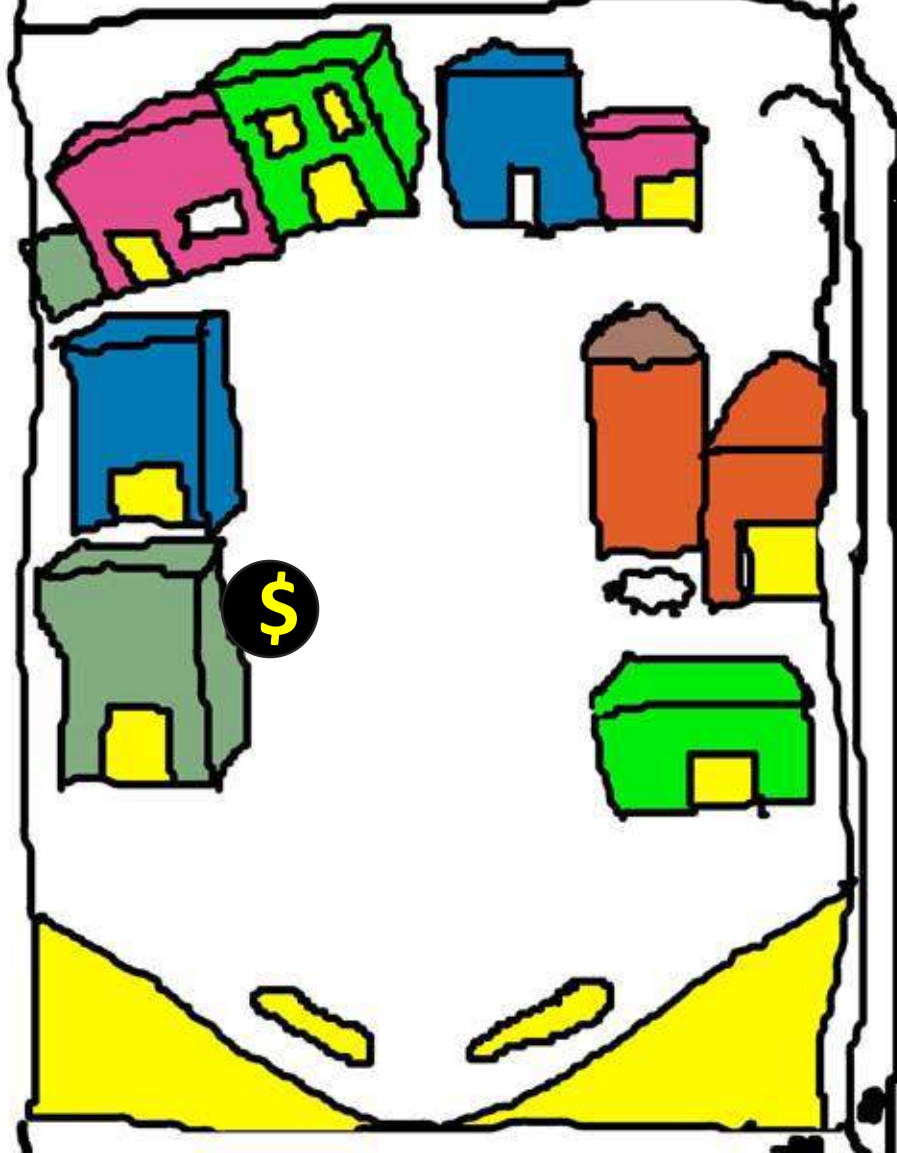

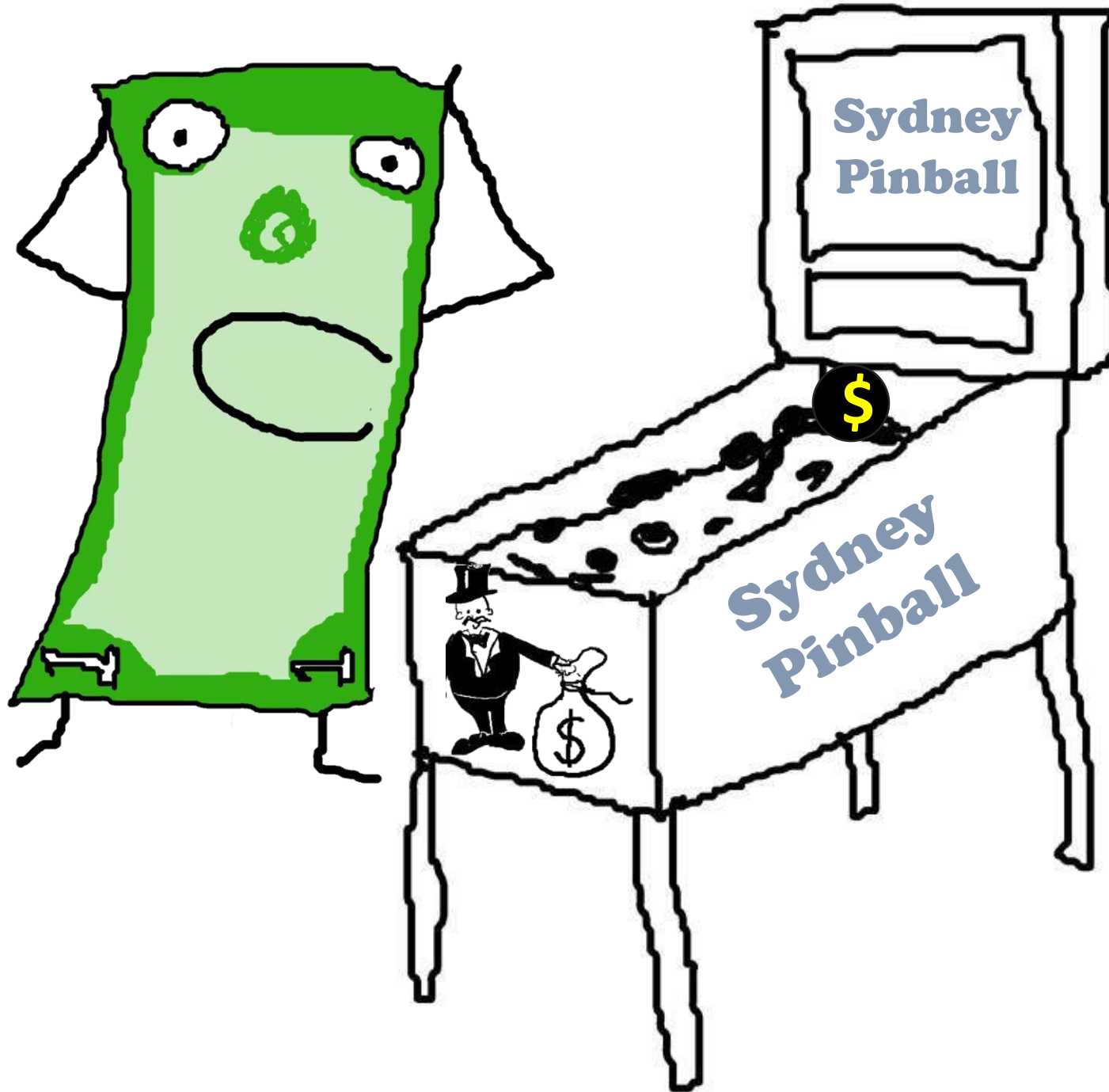

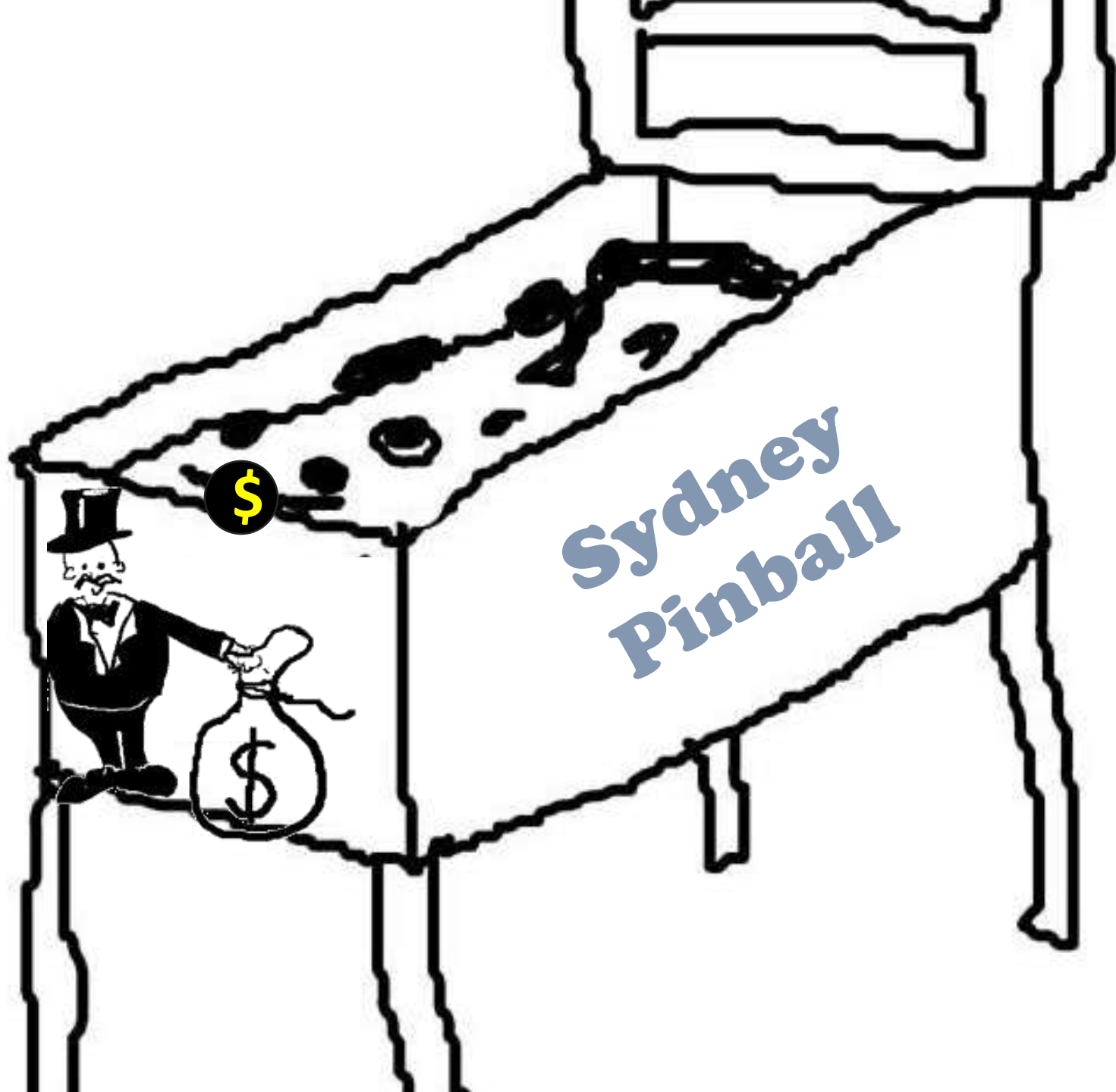
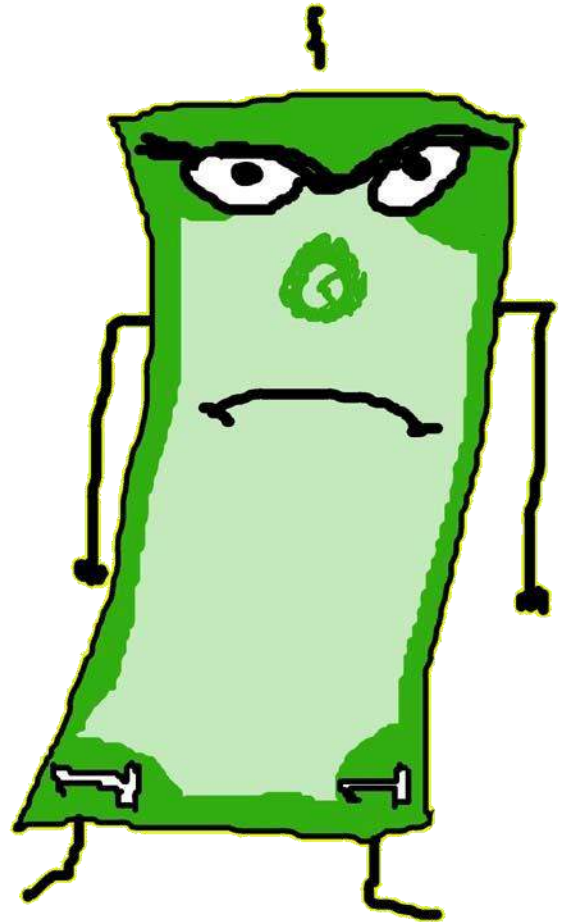

Sydney
Pinball

The future
looks good...

Cohousing Communities
Community Gardens
Social Enterprise
Shared Commercial Kitchens
Carsharing Groups
Ecovillages
Local Currencies
Barter Networks
Time Banks
Land Trusts
Grocery Cooperatives
Worker Cooperatives
Community-Supported
Agriculture
Credit Unions
Etc. Etc. Etc....

...if we make it
look like this!

